



VHF Communications

A Publication
for the Radio-Amateur
Especially Covering VHF,
UHF and Microwaves

J 20 419 F

Digital Signal Processing
For instance: RTTY Modem

Volume No. 21 · Autumn · 3/1989 · DM 7.50

*** YT3MV - RTTY AFSK Asynchronous EX - 11/07/1988 ***

Opt.	Mode	Speed	Space	Mark	Bits	Output File Name
1	ASCII	1200	2400	1200	even-par	UDS4T2 .TXT
2	BAUDOT	45	127	144	unsh-sp	HFRTTY .TXT
3	BAUDOT	45	144	144	unsh-sp	HFRTTY .TXT
4	BAUDOT	45	144	272	unsh-sp	VHFRTTY .TXT
5	BAUDOT	45	144	272	no-par	VHFRTTY .TXT
6	BAUDOT	45	144	272	even-par	HFASCII .TXT
7	BAUDOT	45	144	272	even-par	HFASCII .TXT
8	BAUDOT	45	144	272	even-par	HFASCII .TXT
9	BAUDOT	45	144	272	even-par	HFASCII .TXT
10	BAUDOT	45	144	272	even-par	HFASCII .TXT
11	BAUDOT	45	144	272	even-par	HFASCII .TXT
12	BAUDOT	45	144	272	even-par	HFASCII .TXT
13	BAUDOT	45	144	272	even-par	HFASCII .TXT
14	BAUDOT	45	144	272	even-par	HFASCII .TXT
15	ASCII	1200	2400	1200	unsh-sp	UDS4T2 .TXT
16	ASCII	1200	2400	1200	no-par	UDS4T2 .TXT

16 enter option parameters / add option number
 0=BAUDOT 1=ASCII !=unsh-sp 0=no-par !=even-par !=odd-par

17 enter output file name / add option number

0 or carriage return = exit

Enter option number :



VHF communications

A Publication for the Radio Amateur
Especially Covering VHF, UHF, and Microwaves

Volume No. 21 · Autumn · Edition 3/1989

Published by: TERRY BITTAN OHG, P.O.Box 80,
Jahnstraße 14, D-8523 BAIERSDORF
Fed. Rep. of Germany
Telephone (9133) 47-0 Telex 629 887
Telefax 0 91 33-47 18
Postgiro Nbg. 30455-858

Publishers: TERRY BITTAN OHG

Editors: Corrie Bittan
Colin J. Brock (Assistant)

Translator: Colin J. Brock, G 3 ISB / DJ Ø OK

**Advertising
manager:** Corrie Bittan

**VHF
COMMUNICATIONS**

The international edition of the German publication UKW-BERICHTE is a quarterly amateur radio magazine especially catering for the VHF / UHF / SHF technology. It is published in Spring, Summer, Autumn and Winter. The 1988 subscription price is DM 25.00 or national equivalent per year. Individual copies are available at DM 7.50 or equivalent each. Subscriptions, orders of individual copies, purchase of PC-boards and advertised special components, advertisements and contributions to the magazine should be addressed to the national representative, or – if not possible – directly to the publishers.

All rights reserved. Reprints, translations, or extracts only with the written approval of the publisher.

Printed in the Fed. Rep. of Germany by R. Reichenbach KG
Krelingstr. 39 · 8500 Nuernberg.

We would be grateful if you would address your orders and queries to your representative.

Representatives

Austria

Verlag UKW-BERICHTE, Terry D. Bittan
POB 80, D-8523 Baiersdorf / W. Germany

Australia

W.I.A. P.O. Box 300, South Caulfield, 3162 VIC,
Phone 5285962

Belgium

HAM INTERNATIONAL, Brusselsesteenweg 428,
B-9218 GENT, PCR 000-1014257-25,
Tel. 00-32-91-312111

Denmark

Halskov Electronic, OZ 7 LX, Sigersted gamle Skole,
DK-4100 RINGSTED, Tel. 03-616162, Giro 7 29 68 00

France

Christiane Miché, F 5 SM, SM Electronic,
20 bis, Avenue des Clairons, F-89000 AUXERRE
Tel. (86) 46 96 59

Finland

Peter Lytz, OH 2 AVP, Gæsterbystingen 14 E 49
SF-02410 Kyrkslätt, Tel. 358/0/2 98 17 61

SRAT, PL 44

SF-00441 Helsinki, Tel. 358/0/5626973

Holland

DOEVEN-ELEKTRONIKA, J. Doeven, Schutstraat 58,
NL-7901 EE HOOGEVEEN, Tel. 05280-69679

Israel

Doron Jacobi 424RG, P.O. Box 6382
HAIFA, Israel 31063

Italy

Franco Armenghi, I 4 LCK, Via Sigonio 2,
I-40137 BOLOGNA, Tel. (051) 34 56 97

Luxembourg

TELECO, Jos. Faber, LX 1 DE, 5-9, Rue de la fontaine,
ESCH-SUR-ALZETTE, Tel. 53752

New Zealand

E. M. Zimmermann, ZL 1 AGQ, P. O. Box 31-261
Milford, AUCKLAND 9, Phone 492-744

Norway

Hanning Thag, LA 4 YG, Postboks 70,
N-1324 LYSAKER, Postgirokonto 3 16 00 09

South Africa

Hi-TECH BOOKS, P. O. Box 1142, RANDBURG,
Transvaal 2125, Tel. (011) 886-2020

Spain + Portugal

Julio A. Prieto Alonso, EA 4 CJ, MADRID-15,
Donoso Cortes 58 5^a-B, Tel. 243.83.84

Sweden

Lars Petersson, SM 4 IVE, Pl. 1254, Smögården Talby,
S-71500 ODENSBÄCKEN, Tel. 19-50223, Pg. 914379-3

Switzerland

Terry Bittan, Schweiz, Kreditanstalt ZÜRICH,
Kto. 469 253-41; P/SchKto. ZÜRICH 80-54.849

Leo Kälin, HB 9 CKL, Funktechnik
Alte Landstr. 175, CH 8708 Männedorf

Tel. 01-9203535

United Kingdom

Mike Wooding, G 6 IQM, 5 Ware Orchard
Barby, nr. Rugby, Warks CV23 8UF, Tel. 0788 890365

USA

Timekit, P. O. Box 22277,
Cleveland, Ohio 44122, Phone: (216) 464-3820

©Verlag
UKW-BERICHTE

ISSN 0177-7505



Contents

Matjaž Vidmar, YT 3 MV	Digital Signal Processing Techniques for Radio Amateurs Part 4a: Application Software	130 - 137
Wolfgang Guenther, DF 4 UW	Calculating Antenna-Installation Wind Loading	138 - 144
Andreas Schaumburg, DF 7 ZW	Using Solar Cells to Supply an Amateur Radio Station	145 - 148
Harald Loos, DG 7 NAM	A Review of an Integrated Radio Amateur Program	149 - 156
Ralph Berres, DF 6 WU	Vision/Sound Combiner for AM-ATV Transmitter	157 - 162
Dr. Eng. Jochen Jirmann, DB 1 NV	A Spectrum Analyser for the Radio Amateur Part 3a: Construction and PCBs	163 - 171
Jürgen Dahms, DC Ø DA	The "microline 3" Transverter System The Break-through in 10 GHz Experimental Communications – Part 2	172 - 186
Editors	Briefly Speaking	187 - 189

The **cover illustration** shows one of the many "main menus" of the DSP computer when a user-software diskette is loaded. The question of what in the way of user-software exists is answered in part 4 of the series "Digital Signal Processing Techniques for Radio Amateurs".





Matjaž Vidmar, YT 3 MV

Digital Signal Processing Techniques for Radio Amateurs

Part 4 a: Application Software

The previous three parts of the article about the DSP computer described its principles of operation and its construction. However, from the user's point of view, one of the most important aspects is the available software and the ease of using it. Therefore this additional article is almost necessary, and probably additional articles will be required in the future to describe new available software and/or important modifications to existing software.

4.1. INTRODUCTION

The software for the DSP computer includes the operating system stored in the EPROM and application software distributed on floppy disks. The operating system (actually V7.2) works with program and data files arranged in directories as

on commercial computers. For simplicity there is just one directory for the files stored in the non-volatile RAM and one file directory for each floppy disk.

Application programs are supplied both as source files and as compiled executable files. Source files are provided for users that wish to modify programs or as an example for users who want to write their own programs. Source files can be compiled at any time into executable files using the high-level language compiler built into the operating system software (in the EPROM).

Although executable files require about four times more memory space for storage than source files which are supplied too. Executable files actually contain the values of all the variables. The initialisation of some of these may be quite difficult for the beginner, like typing-in the orbital elements for a number of satellites or setting-up the parameters of a packet-radio program.

As already mentioned in the previous articles, the operating system commands are described in a small manual available separately. This article



```

*** YTDN - SATELLITE VIEWS - 07/06/1989 ***
Screen display select :
1: Mercator projection - full map
2: Mercator projection - fixed zoom
3: Mercator projection - auto zoom

4: satellite view - north up
5: satellite view - satellite direction up
6: satellite view - equianisular projection

Data files :
1: World map file : COAST      .MAP
2: Position file  : TRACK     .DAT
3: Aux map file 1 : EPOCHER   .MAP
4: Aux map file 2 : PRDID     .MAP
5: Printer file  : PRINT      .DAT

Map parameters - full map, fixed zoom & satellite view
Zoom factor      : 2.00
Longitude offset : 10.00 degrees
Latitude offset  : 45.00 degrees
Circle factor    : 2.00 pixel ratio

@ or carriage return = exit
Enter option number / add parameter : █

```

Fig. 2.1.: SATVIEW main menu



Fig. 2.2.: SATVIEW Mercator projection – full map



Fig. 2.3.: SATVIEW Mercator projection – fixed zoom



Fig. 2.4.: SATVIEW Mercator projection – auto zoom

In the case of a wrong command, the "On-line HELP" will appear as in fig. 1.8.

TRACK.SRC is about 21 kbytes long. When compiled into an executable file, it requires about 64 kbytes of memory. The data file is 138 bytes long and includes time, date, satellite name, position and velocity. Future additions to TRACK

may include the tracking of celestial bodies with built-in ephemeris and automatic steering of transceivers for the correction of doppler shifts.

The SATVIEW program can be called from TRACK. It represents the satellite data in a graphical form in a variety of map projections, as shown in fig. 2.1. The first three options will dis-

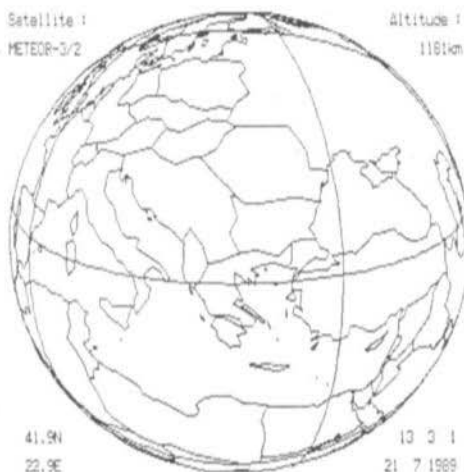

Fig. 2.5.: SATVIEW Satellite view – north up



Fig. 2.6.: SATVIEW Satellite view – equiangular projection



Fig. 2.7.: SATVIEW Satellite view – north up



Fig. 2.8.: SATVIEW Satellite view – equiangular projection

play the acquisition circle on a world map in a projection similar to the Mercator map projection. Either the full world map (see fig. 2.2.), a selected part (fig. 2.3.) or an "auto-zoom" mode (fig. 2.4.) can be selected.

SATVIEW can also draw a view of the Earth as seen from the satellite. The latter can be drawn

as a natural view from the satellite (fig. 2.5. and fig. 2.7.) or mapped into a standard map projection (fig. 2.6. and fig. 2.8.). Note that fig. 2.5. and fig. 2.6. (and similarly fig. 2.7. and fig. 2.8.) cover exactly the same geographical area, only the projection is different. The natural views are useful to check the pictures from an imaging



(weather) satellite while the map projections are useful to find the communications coverage.

How does SATVIEW draw a map? Maps are stored as sets of points in space, each point being described with its three coordinates X, Y and Z. According to the desired projection, the required coordinate transformation is applied first. Then the points are connected with lines to form the drawing. At least one map file and the satellite position file should be available to make the program work. Up to two additional map files can be used too.

Depending on the length of the map files, SATVIEW requires between 1 and 4 seconds to update the picture on the screen. Any picture displayed can be printed: the command "*" will generate a hardcopy printer file that is understood by most standard printers. It may, however, happen that the Earth looks quite elliptic rather than round. In this case the circle factor needs to be adjusted. Experimenting with the hardware in the author's shack, the circle factor had to be set to 1.60 for the TV monitor, to 1.68 for a small dot-matrix printer (Brother M-1109) and to 2.00 for a laser printer (Epson GQ-3500).

Compared to commercial programs (2), SATVIEW runs considerably faster. If compared to

GRAFTRAK running on an IBM clone equipped with the expensive math coprocessor, SATVIEW is between 30 and 100 times faster. Maybe this suggests why it still has sense to make a homebrew computer... Accordingly, it is not necessary to prepare any picture files for animation, for any map projection, since real-time computing is fast enough. In addition it allows a wider selection of projections. On the other hand, some commands have been omitted essentially to keep the user interface as simple as possible: it does have little sense to write a program that requires a thick operating manual no user will ever have the time to read!

SATVIEW.SRC is about 16 kbytes long. When compiled into an executable file, it requires about 59 kbytes of memory. The map files COAST.MAP, BORDER.MAP and GRID.MAP require respectively 70 kbytes, 13 kbytes and 33 kbytes of memory. Future additions to SATVIEW may include additional geographic projections. A different map representation (land and sea of different shades) could be used as well, but the memory requirements grow quickly in the latter case!

Concluding part in the next edition

Interested in AMATEUR TV ?

....then you need CQ - TV Magazine

CQ - TV Magazine is the quarterly journal of the British Amateur Television Club. The club caters for all aspects of television including amateur transmissions, broadcast reception, video techniques, satellites, SSTV etc.

Details of membership may be obtained by sending a stamped addressed envelope to:

**"BATC", 'Grenehurst', Pinewood Road
High Wycombe, Bucks HP12 4DD, U.K.**



Wolfgang Guenther, DF 4 UW

Calculating Antenna-Installation Wind Loading

For general reasons of safety and in particular for eventual insurance claims, every householder should possess the wind-loading calculations for his antenna installation. A subsequent investigation by the claims assessor, upon finding an unauthorized construction, will certainly result in the damage costs falling on the owner of the antenna.

1. INTRODUCTION

It is well-known that every antenna has a wind loading surface which is directly proportional to its mechanical dimensions and which is normally given by the manufacturers. The wind loading may be expressed in various units, e.g. in sq.ft. or in square metres ($1 \text{ m}^2 = 100 \text{ dm}^2$). Modern catalogues use the Newton (N) as the unit of force and a few examples are given in **table 1**.

Conversion: $1 \text{ ft}^2 = 0.093 \text{ m}^2$
 $1 \text{ m}^2 = 10.76 \text{ ft}^2$
 $1 \text{ kp} = 9.8 \text{ N}$

From the known or calculated cross-sectional area of the surfaces exposed to the wind, the wind loading P can be easily obtained. This is dependent upon the wind speed, i.e. from the dynamic pressure (Q) arising therefrom.

If the antenna is less than 20 m above ground or upon a free-standing mast or roof, a Q of 800 N/m² may be expected at a windspeed of 120 km/h.

If the antenna is mounted more than 20 m above ground it may be expected to encounter winds of 140 km/h, i.e. a dynamic pressure Q of 1100 N/m². In exposed areas such as mountains, hills or coastal areas, a wind speed of 160 km/h, i.e. 1440 N/m² should be provided for.

The dynamic pressure Q is proportional to the square of the wind speed v. When the value is not given, it can be calculated from **table 2**.

Many manufacturers give the wind velocity in miles per hour (mph).

Conversion: $1 \text{ km} = 0.62 \text{ land miles}$
 $1 \text{ mile} = 1.61 \text{ km}$



Frequency band and antenna type	at 120 km/h	at 160 km/h
2-m-Yagi 4 element WISI-UY 07	67 N	120 N
2-m-Yagi 12 element WISI-UY 12	105 N	190 N
2 m cross Yagi 10 element Jaybeam 5 XY	105 N	190 N
2 m cross Yagi 20 element Jaybeam 10 XY	198 N	360 N
70-cm-Multibeam, 48 ele. JAYBEAM MBM 48	93 N	170 N
70-cm-Helical, 7 turns, ANDES, circular	69 N	125 N
23-cm-Helical, 10 turns, ANDES, circular	41 N	75 N
24-cm-Long Yagi (ATV) SHF 6964	120 N	216 N
5-Band-Quad 2 ele. v.d.Ley 28-14 MHz	770 N	(0,8 m ²) 1380 N
6-Band Multibeam 7 ele. Sommer XP 507	900 N	(0,93 m ²) 1610 N
6-Band Polybeam 6 ele. FRITZEL FBDX 66	940 N	1690 N
3-Band Polybeam 3 ele. FRITZEL FB 33	400 N	720 N
4-Band Minibeam 3 ele. MINI-PRO. RK 3	143 N	(1,6 ft ²) 257 N
4-Band Miniquad 2 ele. MINI-PRO. HQ 1	134 N	(1,5 ft ²) 241 N
5-Band vertical 1 element HY-Gain 18 AVT	125 N	226 N

Table 1:
Examples of
wind-loading
values for
proprietary
antennas

2. CALCULATIONS

The total wind loading of an array comprises the addition of the individual loadings of all the antennas in the array, the cross-members, outriggers, rotors and the total length of the mast.

A stability rule of thumb has it, that the greatest loading or fracture possibility will occur at the topmost supported point. This loading should never exceed the maximum permitted bending moment of the tube employed.

Examples are given in **table 3** for the strengths applicable, in various directions, for various types of steel.

Dynamic pressure	800 N/m ²	1100 N/m ²	1440 N/m ²
Wind speed	120 km/h	140 km/h	160 km/h
in % of 120 km/h	100 %	138 %	178 %
Multiplication factor	1	1,38	1,78
in % of 140 km/h	73 %	100 %	131 %
Multiplication factor	0,73	1	1,31
in % of 160 km/h	55 %	76 %	100 %
Multiplication factor	0,55	0,76	1

Table 2:
Conversion of dynamic
pressure Q to wind
speed v

Type	Draw - Compression	Bending	Torque	0.9 x Bending (σ)
ST 37	180	180	120	162
ST 42	200	210	140	189
ST 50	220	240	150	216
ST 60	280	300	180	270
ST 70	330	350	210	315

Table 3:
Yield points for various grades of steel (DIN 17100) to forces (N/mm²) to applied in the given directions

The factor of safety of proprietary tubes should be taken as being some 10 % below the values in table 3 (absolute limit $\beta_{0.2}$). This reduced bending moment rating is designated by the Greek letter (Sigma) σ .

From the quotient, bending moment M_B and bending tension $\sigma = (0.9 \times \text{stretch limit } \beta_{0.2})$ the resistive moment W_B is obtained for the bending moment at the point under consideration

$$W_B = \frac{M_B}{0.9 \beta_{0.2}} \quad \text{in cm}^3 \quad (1)$$

$$W_B = \frac{\pi}{32} \cdot \frac{(D^4 - d^4)}{D} = \frac{D^4 - d^4}{10 D} \quad \text{in cm}^3$$

where $D =$ external dia in cm
 $d =$ internal dia in cm (2)

$\emptyset D/d$ in mm	W_B in cm ³
32 / 28	1,36
42 / 38	2,44
45 / 40	3,4
50 / 46	3,54
48 / 43	3,94
50 / 40	7,38
60 / 52	9,41
60 / 50	11,15
76 / 70	12,30
100 / 92	28,36

Table 4: Section modulus of various tube diameters

The larger the tube's cross-sectional area is, the greater is its ability to withstand a given bending moment. This important rating may be determined for all proprietary antenna tubing (examples in table 4) by the following calculations.

Combining formulae 1 and 2 the four quantities may be obtained: -

$$M_B = \frac{0,9 (D^4 - d^4) \beta_{0,2}}{10 D}$$

as well as D , d and $\beta_{0,2}$

The bending moment at a given point is not known as a rule but it may be obtained from the product of the wind loading and the height of the free-standing mast.

$$M_B = P_R \times H/2 = 1.2 DQH \times H/2 = 0.6 DQH^2 \quad (3)$$

where $D =$ the tube's external dia
 $H =$ the total height of the mast
 $Q =$ the dynamic pressure at a given wind speed

The factor 1.2 is the CW value of a tube. Table 5 gives examples of permissible bending-moments according to DIN 0855.

The permissible antenna wind loading is obtained after deducting the wind load due to the mast tube and by that of the rotor mounting on the mast.



ext./int ø	max. bending moment
ø 32/28 mm	400 Nm
ø 42/38 mm	720 Nm
ø 48/43,4 mm	1080 Nm
ø 48/43 mm	1160 Nm

Table 5: Examples of the permitted bending moments for various steel tubing (ST 60-2)

If the calculated maximal antenna wind loading is not sufficient, then a tube of greater diameter must be employed. On no account should more antennas be mounted on a mast that is being supported by only one set of guy ropes or support bearings. The guy ropes should not be included in any stability calculations at all. The purpose of guy ropes is: –

1. They should inhibit mechanical oscillations – which could have a resonant frequency. A resonant condition could quickly lead to the destruction of a properly calculated antenna system.

2. Inhibit undue movement of the mast swaying in the wind could also be the cause of signal variations on the radio link in both send and receive directions – apart from considerations of mechanical stability (see the article by Ewald Schleenbecker, DK 9 ZN, in the German magazine CQ-DL 5/82).

The following wind loading formulae are applicable: –

$$P_{1/2} = (H_{1/2} \cdot P_{100\%}) / H_{100\%} \quad (4)$$

where $H_{100\%}$ is the total height

$P_{100\%}$ is the given wind loading

$H_{1/2}$ is the height of the antenna above the guyed point or support bearing.

The wind loading P for a steel tubular mast: –

$$A = DH \text{ is } P_R = 1.2 AQ \quad (5)$$

The total wind loading is simply the sum of all the individual wind-loadings: –

$$P_{tot} = P_1 + P_2 + P_3 + P_{4...} \quad (6)$$

Unfortunately, manufacturers seldom give data about the maximum permissible wind loading of their mast tubing. More often, only data concerning the maximum bending moment or just the type of material is given.

Calculating the bending moment of individual antennas is very simple. The given wind load of the antenna is multiplied by the height at which the antenna is mounted above the guying point (or support bearing). The total bending moment at the guyed point is then the sum of all the individual bending moments of the antenna, cross beams, the rotor and the mast tubing itself.

$$M_{B_{tot}} = P_1 H_1 + P_2 H_2 + P_3 H_3 + \dots \quad (7)$$

Using the manufacturers given value for $\beta_{0.2}$ (Beta 0.2) or σ (Sigma) it is also possible to calculate the total permitted axial load that a tube will withstand. The formulae 1 and 2 are used as well to obtain the maximum permissible bending moment of the tube at the guyed point.

The bending moment of the antenna is calculated using formula 7 and it is compared with the result above for verification.

3. REGULATIONS

The height of the antenna installation will normally be restricted by regulations.

According to VDE 0855, corresponding to DIN 57855, antennas may be constructed on a single tube of no higher than 6 metres whereby the total bending moment (at the clamped point) can on no account exceed 1650 Nm. The minimal clamped length is 1/6 of the total length of the tube. Even when the free length above the clamped point is no more than 1 metre, the sum of all the wind loadings (times the height) should not exceed this value.

All constructions, whose values exceed these two limits, require a static calculation and certificate from a structural engineer. This particularly applies for lighting or power masts of from 10 to 20 metres in height.



4. EXAMPLE

A practical example will now be considered. This is pictured in **fig. 1** and a planning diagram is shown in **fig. 2**.

The mast comprises two sections of 2 metre long "plug and socket" tubing of 48 mm external diameter and 43 mm internal diameter. Both tubes are affixed axially and supported at a point 2.5 metres from the top of the installation. A HQ 1 is mounted at the top i.e. 2.5 metres above the support bearing and a 2 metre cross-Yagi and a 70 cm Helical antenna are both mounted 1.5 metres above the support bearing (see **fig. 2**). Ignoring the structural considerations, it is better from an RF point of view to place the shortwave antenna above the UHF antenna in order to obtain better radiation characteristics.

This arises because the 14 MHz antenna mounted only 0.5 metres above the roof level would correspond to a 144 MHz Yagi mounted only 5 cm above the roof's surface, when seen from an electro-magnetic field point of view. The proximity of the roof at this height would totally modify the angle of shoot of the HF antenna.

As the subject antenna installation is mounted on the roof of a house 10 metres above ground level and in a relatively sheltered situation, the wind pressure was fixed at 800 N/m^2 at a wind speed of 120 km/h and for a height of max. 15.5 metres of the HF antenna.

Antennae data:

70 cm Helical with 7 turns: $P1 = 69 \text{ N}$

2 m Cross-Yagi with 16 elements: $P2 = 160 \text{ N}$

According to the rules, the antennas at a height of 1.25 m above the support bearing is half that of the total mounting height of 2.5 m and this corresponds therefore to about half the above data $P1 = 35 \text{ N}$ and $P2 = 80 \text{ N}$. The manufac-

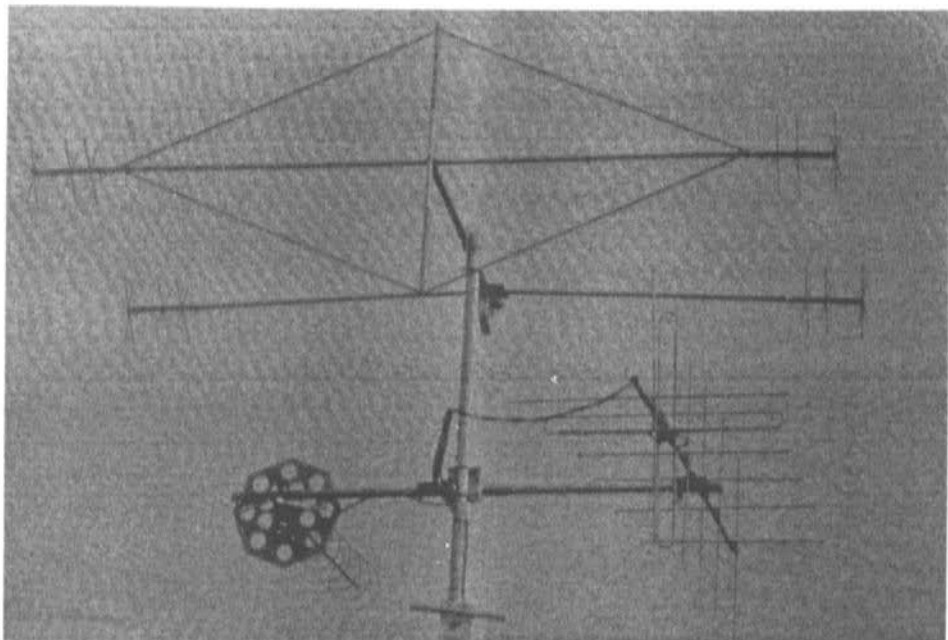

Fig. 1: The antenna which is the subject of the stability calculations

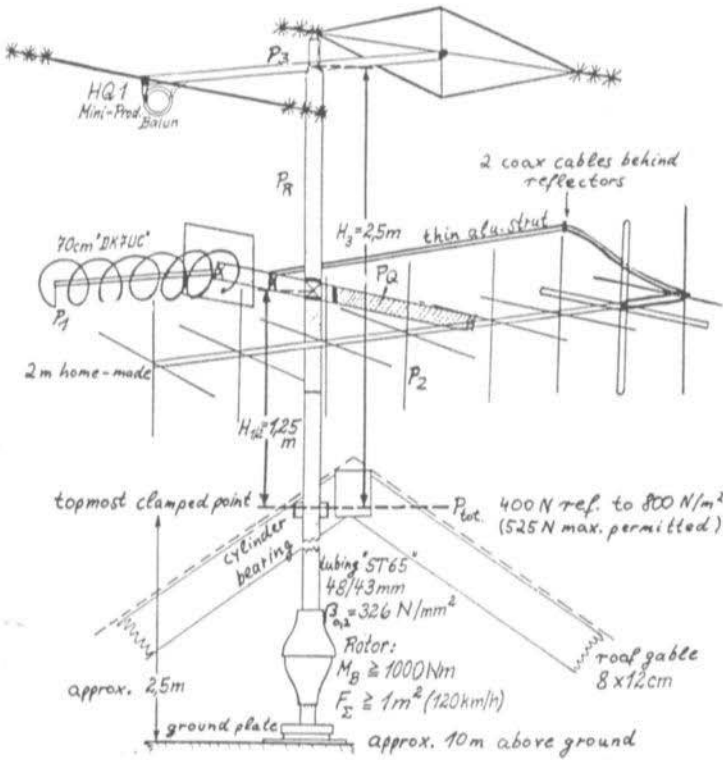

Fig. 2: Dimensional diagram of the subject installation shown in fig. 1

turers data (table 5) shows the tube of length 2.5 m capable of withstanding an antenna wind loading of 410 N (max).

The shortwave antenna is mounted at the full height of 2.5 metres and is subject to the full wind loading. As the antenna was manufactured in USA, the given data had to be converted to metric.

$$1.5 \text{ ft.}^2 \triangleq 1.5 \times 0.093 \text{ m}^2 = 0.14 \text{ m}^2$$

$$P_3 = 0.14 \text{ m}^2 \times 800 \text{ N/m}^2 \times 1.2 = \mathbf{134.4 \text{ N}}$$
 from (5)

The cross boom carrying the two UHF antennas is also subject to half the wind load as it is mounted at 1.25 m.

With A = DL and (5) gives for a 48 mm tube: -

$$P_Q = 1.2 \text{ DLQ} = 0.048 \text{ m} \times 1.5 \text{ m} \times 1.2 \times 800 \text{ N/m}^2 \times 0.5 = \mathbf{34.5 \text{ N}}$$

The wind loading of the mast tube is also calculated from formula 5:

$$P_R = 1.2 \text{ DLQ} = 0.048 \text{ m} \times 2.5 \text{ m} \times 800 \text{ N/m}^2 \times 1.2 = \mathbf{115 \text{ N}}$$

(The wind loading of the tube has already been subtracted in table 6)

The total wind load of the installation is then

$$P_{\text{tot}} = P_1 + P_2 + P_3 + P_Q + P_R = 399 \text{ N}$$

This value of about 400 N lies well below that of the maximum permissible antenna wind loading of 525 N. Either a small parabolic dish antenna could be added, or the HF antenna can be considered as safe at a wind force of up to 120 N - either could be contemplated with this amount of spare loading to play with.

A parabolic dish mounted at 1.7 m has a wind load of 176.5 N according to formula 4.



By using formula 5 and the formula for the area of a circle $A = \pi r^2$, the diameter of the dish may be calculated: -

$$r_s = \sqrt{\frac{P_4}{1.5 \pi Q}} =$$

$$\sqrt{\frac{176 \text{ N} \cdot \text{m}^2}{1.5 \pi 800 \text{ N}}} = 0,216 \text{ m}$$

$$D_s = 0.43 \text{ m}$$

If instead, a 0.5 m dish antenna is used, it may only be mounted at a height of 1.4 m (max.).

Another method of calculating the above example is to add the individual bending moments according to formula 7.

$$\begin{aligned} M_{B \text{ tot}} &= 69 \text{ N} \times 1.25 \text{ m} + 160 \text{ N} \times 1.25 \text{ m} + \\ &+ 134.4 \text{ N} \times 2.5 \text{ m} + 69 \text{ N} \times 1.25 \text{ m} + \\ &+ 115 \text{ N} \times 1.25 \text{ m} = 852 \text{ Nm} \end{aligned}$$

free length	max. antenna wind load
1,5 m	1140 N
1,5 m	740 N
2,0 m	540 N
2,5 m	410 N
3,0 m	320 N
3,5 m	260 N
4,0 m	210 N
4,5 m	170 N
5,0 m	130 N

Table 6: Permissible wind loads for various guyed (supported) antenna heights using 48/43 mm tubing

This value is still smaller than the maximal permitted bending moment for our 48/43 mm tube of 1160 Nm. This means that the construction is permitted.

This means of calculation also shows that the installation could be additionally loaded with a small parabolic dish.

$$M_{sp} = 176 \text{ N} \times 1.7 \text{ m} = 299 \text{ Nm}$$

$$M_{tot} = M_{B \text{ tot}} + M_{sp} = 1152 \text{ Nm}$$

A must for all active and technically minded Radio Amateurs!

THE UHF-COMPENDIUM

The English edition of the well-known "UHF-Unterlage" from Karl Weiner, DJ 9 HO.

Part 1 and 2

Art.No. 8054

DM 45.00

Part 3 and 4

Art.No. 8055

DM 54.00

Additional post and package charges (surface mail) for inland DM 5.00, for abroad DM 6.50.



Telecommunications, VHF-Communications - UKW-Technik Terry D. Bittan
Jahnstraße 14, D-8523 Baiersdorf, Telefon (09133) 4 70, Telex 629887



Andreas Schaumburg, DF 7 ZW

Using Solar Cells to Supply an Amateur Radio Station

A solar generator can be used to supply all the energy required to operate a radio amateur station by converting the Sun's energy into electrical current. The initial cost of a solar generator is relatively high but the subsequent running costs are low. The Siemens solar module SM 18, for example, costs about DM 350.— but is able to supply approximately 17 kWh per year.

The following article will describe the salient elements of a solar installation; solar module, storage battery and charger together with a few items gathered from the author's experience in their operation

1. THE STORAGE BATTERY

The accumulator stores the electrical energy by day through the solar module which converts light energy, even in the absence of direct sunshine, into electrical current. Usually, ordinary lead-acid batteries are employed for the storage cells. Car-starter batteries are good enough to be employed here as purpose-built batteries tend to be very expensive.

In their use in a solar energy supply installation, the accumulators are not particularly stressed. No great charging currents are generated and there is a complete absence of the vibration that a car battery would normally experience. A car

battery can be expected to last for 50 to 100 full charge and discharge cycles. Discharges of only 50 % result in this figure rising to about 500. Very heavy discharges are therefore, in the interests of battery life, to be avoided.

Only accumulators with readily openable caps should be employed in order to facilitate topping-up with distilled water and occasionally acid, also that the specific gravity can be measured for each individual cell. The cell is fully charged when the acid content has a density of 1.28 g/cm³ and fully discharged with an acid density of 1.12 g/cm³ at an ambient temperature of 27° C. The cell voltage of an individual lead-acid cell is: —

$$\text{Acid density (grammes/Cu.cm)} + 0.84 \text{ V.}$$

This relationship occurs when the cell is quiescent, i.e. neither being charged nor discharged. Through it, the charge condition can be interpolated by a knowledge of the battery terminal voltage, see fig. 1.

The maximum terminal voltage of lead-acid accumulators during a prolonged charge is temperature dependent. At 20° C it is 2.35 V per cell, at 0° C it is 2.5 V and at - 20° C it is 2.6 V.

At this cell voltage the accumulator is fully charged and cannot accept any more energy. An excess cell voltage due to a further increase in charging energy will result in gassing of the electrolyte. The excess energy causes electrolysis action which splits the water in the weak acid solution into oxygen and hydrogen, a proc-

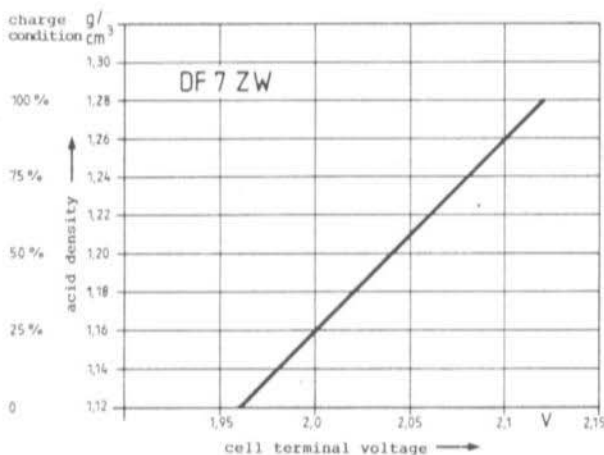

Fig. 1:
The cell terminal voltage
and charge condition of a
lead acid battery at a 27° C
ambient temperature

ess which is damaging for the plates. An energy requirement of 3 Ampere hours is necessary to gas-off 1 g of water per cell. Excessive charging of the battery must therefore be inhibited by means of a charge regulator. A slight over-charging with about 1 % of the rated capacity current can, however, be tolerated. This sort of over-charging could occur using solar cells during sun-light conditions.

The charge loss of an unloaded accumulator is relatively small, especially at low temperatures. Below 0° C, half the energy of an unused battery is still available 24 months following a full charge. This is very advantageous as in winter the solar energy is much smaller than in summer. Self-discharging of the cells in winter need not, therefore, be taken into consideration when estimating the energy equations for the station.

Care must, however, be exercised when the battery is discharged in low ambient temperatures. At an acid density of 1.16 g/cm³ the electrolytic can freeze, at a temperature of - 20° C, leading to the physical destruction of the battery case.

The author has, on the whole, had very positive results with car starter batteries. If the cells of a battery have widely differing specific gravities, a condition which is not able to be corrected by a

long mains charge, it is possible that some of the cells are defective. Towards the end of the battery's life, the particles of lead from the battery plates which have accumulated on the floor of the cell, reach a sufficient quantity to form a short-circuit across the plates. The specific gravity of the affected cell falls quickly and can easily be detected with a hygrometer. If batteries are worked in parallel, these defective cells must be repaired or removed, otherwise it could lead to the good shunt batteries being discharged as well. Under working conditions, worn-out cells are characterized by their constant need to be topped-up with distilled water. When this is noticed the battery should be replaced.

2. THE SOLAR MODULE

There are several types of solar modules. The well-known, established form, is a module of mono-crystalline, silicon. A 12 volt requirement would comprise 36 or more of these cells in series. The Siemens SM 18 or SM 36 is such a module. A later module uses what is known as the thin-film technology. Several silicon layers are



Month	Duration of sunshine
January	0.9 h per day
February	1.7 h per day
March	2.6 h per day
April	3.6 h per day
May	4.3 h per day
June	4.3 h per day
July	4.3 h per day
August	4.3 h per day
September	4.0 h per day
October	2.0 h per day
November	1.05 h per day
December	0.75 h per day
1030 hours per year	

Table 1: Statistically average duration of sunshine in Germany (module canted 45°, direction: south).

sputtered onto a thin glass disc and they are then cut into 25 strips with a laser beam. The individual cells thereby produced are all connected in series and encapsulated into a module. The advantage of this technique is the low manufacturing cost and the disadvantage is its low working life, about 5 years. Siemens are currently giving a life-span of 30 years for their modules on a mono-crystalline base.

The duration of sunshine which can be expected throughout the year is tabulated in **table 1**. The author obtained this information from several sources and changed them all into common units. The time that, statistically, the module is in full operation, is given for each month of the year. The values given, (just for Germany), are relevant for a module which is canted at an angle of 45° in a southerly direction. This angle ensures that the module is washed by rain and also allows no snow to remain long on its surface. Bird droppings can be guarded against by wire drawn 2 to 4 cm above the top edge of the module thus preventing it from becoming a natural bird perch.

In order to prevent the cells from discharging back through the load during the hours of darkness, a diode is connected between solar module

and battery installation. This diode could be of the Schottky variety as this has a low voltage drop across it in the forward direction.

An example will now be considered which will show how the capacity of the storage batteries is arrived at: -

Assuming that a solar module SM 18 with a maximum current of 1.2 Amperes is used to supply a yearly energy requirement of 2 Ah per day:

$$2 \text{ Ah} \times 365 \text{ days} = 730 \text{ Ah}$$

The module produces per year:

$$1.2 \text{ A} \times 1030 \text{ h} = 1236 \text{ Ah}$$

It will be seen that altogether 500 Ah more will be produced than is actually expended and this will adequately maintain the storage batteries. The energy requirement in the winter months of November to January is, however, higher than that produced.

The resulting energy deficit results in a battery discharge and is estimated as follows: -

November	30 (2 Ah - 1.2 A x 1.05 h) = 22.2 Ah
December	31 (2 Ah - 1.2 A x 0.75 h) = 34.1 Ah
January	31 (2 Ah - 1.2 A x 0.9 h) = 28.5 Ah

Total energy deficit	= 84.8 Ah
----------------------	-----------

From this calculation it is apparent that the storage battery should have a capacity of at least 85 Ah. The author uses a 180 Ah battery in his solar-cell charging system. The use of an over-dimensioned storage battery is advantageous as it will ensure that all energy requirements are met even in the prolonged overcast days of winter.

3. THE CHARGING CONTROL

The charging control is necessary in order to prevent over-charging the battery. There are several circuit variants which are capable of charge control. There are two main principles which can be used to achieve this purpose: -

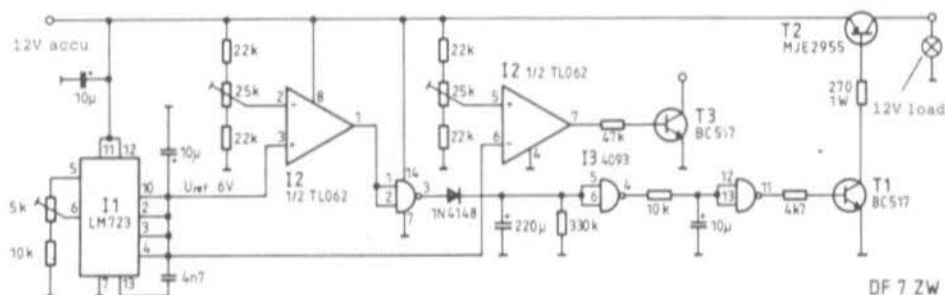

The series pass regulator which represents a regulated variable resistor between the solar cells and the storage battery. The value of this resistor varies in accordance with the state-of-charge of the battery and thereby controls the supply of current from solar cell to battery.

The parallel, or shunt, regulator is connected in parallel across the battery and dissipates the superfluous current from the solar cell, as heat. The solar cell is always fully loaded when the regulator voltage exceeds the 14.2 V maximum charging voltage limit and an additional dissipation load, e.g. a lamp, is switched into the circuit by the regulator.

A simple shunt regulator circuit was developed which uses readily available components. It is shown in **fig. 2** and it is easily tailored in order to meet the requirement at-hand. The integrated circuit LM 723 supplies the reference voltage which is trimmed to 6 V by the 5 k Ω pre-set pot' meter. The two halves of the dual OP-AMP TL 062 form two comparators. One of which has a threshold of about 11.5 V which is used to shut-down the regulator in the case of a load fault. The other comparator is set to 14.2 V, the charge voltage limit. The former facility is something of a circuit luxury but it gave the second half of the available OP-AMP something useful to do.

The IC 4093 is used in a timing circuit. It causes an additional load, of say a 12 V, 18 W lamp, to be switched across the load for 70 seconds following a voltage exceeding 14.2 V.

The current supply to the regulator is only minimal (2.5 mA) during quiescent conditions and so makes no great demands upon the solar cells.

In winter, during prolonged overcast weather, however, the author removes the regulator in order to preserve the battery charge as much as possible. A small over-charge of the battery in winter is unlikely to cause any great battery deterioration.

4. REFERENCES

- (1) H.K. Köthe: Praxis solar- und wind-elektrischer Energieversorgung VDI-Verlag
- (2) W. Garten: Bleiakumulatoren Varta Fachbuchreihe Band 1 Gasdichte Nickel-Cadmium-Akkumulatoren Varta Fachbuchreihe Band 9



Harald Loos, DG 7 NAM

A Review of an Integrated Radio Amateur Program

A comprehensive operational and service program for radio amateurs has been developed for ATARI ST series computer users. This program represents a continuous and convenient aid for radio operations and can also support the record and file-keeping necessary for an amateur radio station.

The following article aims to review the performance highlights of this software and then a few program specific features will be gone into detail.

The basic aim of the program author, Wolfgang Cramer, DK 4 BV, was to produce a single program that includes most of the possible requirements that are necessary for the radio amateur. The realisation of this aim was only possible following the introduction of powerful personal computers such as the ATARI ST.

The performance of the ATARI ST (68000 processor) is considered to be well above most of the IBM compatible class of personal com-

puters. It offers the user advanced technology instead of the compatibility to other systems whose hardware nowadays is behind that of the technically feasible. Such an advanced computer is purchased, despite the restriction in the available off-the-shelf software, for authors of software and program specialists. This type of person is very well served with the ATARI ST.

The ST's operational system is called TOS (Tramiel Operating System) and one can only say that it is a high-class system deriving from an amalgam of MS-DOS and CP/M-68 but incompatible with any other commercially available system — as already mentioned above. There are, however, various software emulations available.

A further important feature available is the GEM (Graphic Environment Manager) with which this type of computer is fitted. The AFU program (fig. 1) also operates at this level. For those unacquainted with any operational system, this program represents a considerable simplification as it is no longer necessary to give commands in the form of text, instead, the so-called pull-down menus are employed. These give a choice



Fig. 1:
Printout of the pull-down
menus 1 and 2

of various possibilities which are selected by a MOUSE pointing device.

The integrated AFU program is written in the GFA-BASIC program language and then compiled for an increase in speed. Now, the performance characteristics will be considered.

At system start, a RAM disc is automatically generated and loaded with all the necessary data. This is a "virtual" disc drive, which means that a portion of the ample available memory is reserved for this purpose. This enables fast access to the data stored within it.

1. SYSTEM START

After the compiled program has been called up, the system parameters for date and time are displayed (fig. 2). These can now be entered and thereby brought up updated. Where a hardware system clock is fitted, RETURN is pressed twice. Date and time are required in several parts of the program as preset values.

2. MENU 1

"Menu 1" is the term used to describe the first part of a two-part menu table. Because of the comprehensive nature of the functions, it was not possible to display all the feature titles of the pull-down menus on a single screen display. Therefore Wolfgang, DK 4 BV, decided upon a two-part division.

AMATEUR RADIO PROGRAM

DE DK4BV

Please put in current date like (DD.MM.YY) : 17.08.89

Please put in current time like (HH.MM) : 22.45

or go on with [RETURN] = take over of system datas

Fig. 2: Input window for date and time

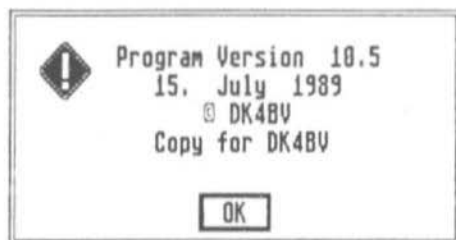

Fig. 3: The customized data of a purchased program

Selecting the first item in "Menu 1", a box displays containing the valid version number, the date of the program compilation and the callsign of the owner (fig. 3).

2.1. Gen. PRGs

A background feature of this menu is a "Callsign Management" program which has its own data bank. This program automatically contains all initial contact callsigns.

Should the callsign data file be missing, an error indication is displayed together with the possibility to generate these data as the program progresses.

Following the entry of the callsign into the input box, the computer looks into the data bank. Either the relevant data such as name, date, location, frequency, antenna heading, distance etc are displayed (fig. 4) or a new input is offered.

At the entry of the date and time, as well as calling the input and output of the QSL cards, the preset data can be accepted.

A second step enables the compilation of a logbook following the first contact. This effectively means that further inputs are added under the existing callsign.

The final standardization of the inputs for subsequent data-bank interrogations is affected by storing and can be observed by calling them up again. This process normalizes the inputs so that they are all capital letters or missing zeros are added for date, time, or frequency inputs.

The data-bank interrogation can be effected via the menu facility "Callsign Selection"; for example, the display of all G3...callsigns whose first names are "John" and the QSO took place in 1985. In this manner the initial-contact data bank can handle up to 11 and the logbook data bank up to 6 chosen inter-related criteria (fig. 5).

The normal QTH locator/identification systems, used in radio amateur circles, can be employed

Menu_1	Gen. PRG's	Com PRG's	Baudrate	Protocol	Com Keys	Menu2/Quit
()	CALLSIGN :	DG7NAM		(02) DATE	:	28.03.88
(03)	NAME :	HARALD		(04) TIME	:	20.38
(05)	CITY :	WÜRNBERG		(06) ORG (MHz):	:	144.850
(07)	MW-LOC. :	JMS9MI		(08) EU-LOC. :	:	FJ56h
(09)	DOK :	B11		(10) MODE	:	FM
(11)	RST out :	53		(12) RST in	:	52
(13)	OSL out :	N		(14) OSL in	:	N
(15)	OTHERS :	ATARI ST				
()	ANT-DIREC:	213 °		() DISTANCE :	:	11 km

Change [Number], Delete [Delete], Logbook [L], go on [*]
or back to menu with [ESC] _

Fig. 4:
Example of a callsign
log in the data bank



```
Menu_1 Gen. PRG's Com PRG's Baudrate Protocol Com Keys Menu2/Quit
```

```

Strings of Selection
-----
(01) Callsign      : DK
(02) Date         :
(03) Frequency    : 145
(04) Mode         :
(05) QSL out      :
(06) QSL in       : Y

(07) Name         :
(08) City         :
(09) MW-QTH-Locator :
(10) DQK         :
(11) Others       : ATARI ST

(12) Start Selecting:
(13) Total Output  :

Please put in (1-13) : _
Break with [ESC]

```

Fig. 5:
A data bank
enquiry

Strings from 07 to 11 are not effective in the logbook database!

under the menu title "WW-QTH-Calc.", "EU-QTH-Calc." and "Co-ordinate Calc.". Data inputs for any one of these three facilities results in the other two being updated together with a computation of the antenna heading.

To support the antenna heading for the rotor alignment feature, information of the rotor position is displayed graphically in order that it may be immediately seen, where say, a heading of 300°

lies without having to think about it too much (fig. 6).

Finally, there is the possibility of contest log-keeping. This part of the program is divided into an input and an output.

The date and time, having been entered at the start of the session, are automatically put into the input part of the program, from the system.

```
Menu_1 Gen. PRG's Com PRG's Baudrate Protocol Com Keys Menu2/Quit
```

```

Put in World Wide QTH Locator : jo32gt

Antenna direction is 318 Degree
Distance is 493 km
European QTH Locator is DM13j
Co-ordinates: 6°32.5' Length 52°48.75' Width

```

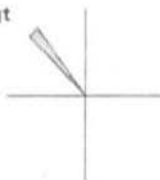

```

Program repetition with [M]
or back to menu with [ESC] _

```

Fig. 6:
Location and distance
calculation together
with heading display



Menu_1 Gen. PRG's Com PRG's Baudrate Protocol Com Keys Menu2/Duit

```
( ) CALLSIGN : DK6XD          ( ) ORG(Band): 80
(03) RST out : 59 001        (04) RST in  : 59 003
(05) MW-LOC. : J053F0       (06) EU-LOC. : FN23g

(07) OTHERS  : TEST         (08) TIME    : 20.23

( ) MODE     : SSB          ( ) DATE     : 20.03.88
( ) ANT-DIREC: 354 °       ( ) DISTANCE : 475 km
```

Change [Number], Delete [Delete], go on [*]
or back to menu with [ESC] -

Fig. 7:
Example of a
contest log

Following the initial inputs, the working band is requested and can either be accepted or overwritten with RETURN. A progressive numbering starting from 001 is effected automatically (fig. 7). All these measures serve to speed up the input which can be of great importance in a contest. There is also the possibility of provisionally entering into another part of the program in order, for example, to look up a file and then revert straight back to the contest log.

An evaluation of the contest can only be made when all the receive and code data as well as the QTHs are complete.

2.2. COM-PRGs and Baud Rate

For the communications programs TNC, an AMTOR or an RTTY converter must be connected at the serial interface. With the exception of RTTY, a software solution is not available for these operational modes. Without supplementary equipment, however, it cannot be carried out anyway.

When under "COM-PRGs" e.g. RTTY (Baudot) is clicked up, the 45.5 Baud speed 80 character mode can be immediately brought into operation.

The monitor display is switched over automatically to capital letters, the numeral/literal switch-over takes place automatically as well. Even the send/receive switch-over is possible by use of the computer keyboard.

When engaged in an RTTY QSO and a callsign is encountered which is not immediately identifiable, the MOUSE is used to select "Gen. PRGs" (the "Callsign Management") in order to swiftly verify whether or not the contact station is known. The program is returned to the current contact right after this enquiry, shows the latest screen content, and displays any information which may have arrived in the meantime.

All 10 function keys are doubly utilized in order to ensure a fast processing of radio traffic.

The same possibilities as for RTTY exist also for PR, whereby the preset Baud rate to the computer should not be confused with the 1200 Baud which is being given from the TNC to the radio equipment.

The split-screen operation can be separately switched on and off. The upper portion of the divided screen displays the received and the lower portion, the transmitted text (fig. 8).



Menu_1	Gen. PRG's	Com PRG's	Baudrate	Protocol	Com Keys	Menu2/Quit
		✓ PR / ASCII PARRATT Operation				
		RTTY (Baudot) RTTY (64-C-Mode)				
		✓ Split/Full-Screen				
-----0-						
:-----0-----0-						
1 /DK4BV 0 /DK6XD 0 /D02HZ 0 //LNDU/X/RL/0						
:DBB8BH0 DFBH0 0 -6J						
.DBB8BH0 DFBH0 0 -6J						
sddk6xd						
svdd2hz						
s						

Fig. 8:
Example of the screen
contests for a packet
radio operation

2.3. Protocol

If a copy of the proceedings is required, the appropriate point under "protocol" is clicked up and a copy is received either on a diskette or on paper.

Upon copying to a diskette, a file PROTOCOL DOC is installed which is able to be viewed at any time without transmitting it – just like any other file. Even subsequent word-processing is possible.

In order that matching to converters of various types can be carried out, the RS 232 C's interface transfer-protocol can be changed.

2.4. Comm-Keys

In communications programs, under "Comm-Keys", can be found the allocations for some special keys used for storage, deletion, viewing and transmission of files. First of all, however, the drive is chosen.

Furthermore, there exists the possibility to transmit self-formulated ASCII files with the "shift" and a function key.

2.5. Menu 2/Quit

If, when in RAM-DISC operation, the program is properly exited via "Quit", and after the verifying enquiries, the changed or newly installed files are stored on floppy or hard discs.

Beyond these functions, a second menu can be called-up which will now be described.

3. MENU 2

3.1. Repeaters, Beacons and Mailboxes

Repeaters and Beacons have files in which relevant enquiries can be made or even updating can be carried out.

Repeater and Beacon callsigns can be used several times on various frequencies. They can be differentiated by using a progressive numbering system, starting with number 1.

Upon data-bank enquiries under the column "Radius of", it is possible to determine which



Menu_2 Repeaters Beacons Mailboxes Orbit Listings Other



Fig. 9:
Example of data and
graphic calling up
OSCAR 13

```

OSCAR-13
-----
Date      17.7.1989
Time (UTC) 16:18:02

# of Rotations  837
Distance (km) 37941

Azimut  ( °)  132
Elevation ( °)  51
Mean Anoma. 129
Mean Anoma.( °) 181

 2 m-Shift (Hz) 186
 70cm-Shift (Hz) 317
 23cm-Shift (Hz) 921
  
```

New calculation with [*]
or Break with [ESC]

of the repeaters and beacons are available in the region selected.

3.2. Orbit

Under "EME Power" can be calculated what conditions are necessary for an EME contact.

Under "Moon Pos." it is possible to calculate the actual position of the moon for EME operation.

Under "Sat. Pos." the actual position of any satellite can be determined and the data relevant for the contact can be obtained. At the same time, the earth's surface as seen from the satellite and thereby the radio footprint is displayed (fig. 9).

Under "Sat. Overv." an overview is obtained of all the 22 satellite orbits so far programmed. The current satellite's name is necessary to be entered for a position computation to be carried out (fig. 10).

Finally, the orbital data for any satellite can be entered, in the form of Kepler Elements.

3.3. Listings

The shortwave and VHF-band plans, the repeater and linear transponder frequencies, as well as the countries accepting the CEPT standard are fixed in the program. No user corrections are normally possible. The DXCC countries, on the other hand, can be displayed and updated.

3.4. Other

Under "Other" (miscellaneous), normal or inverse display may be selected. "Free Disk Cap." shows how much disc space is still available together with the free capacity in the main memory – the latter information being of greater importance when using RAM-DISK rather than the diskette.

For prospective HF radio-amateur licence candidates or those desirous of speed training, a "Morse Trainer" is included in the program. This either delivers random groups of five or Ham abbreviations in 20 to 120 characters per minute, or keyboard – entered text is automatically con-

Menu_2 Repeater Beacons Mailboxes Orbit Listings Other

 Overview of Saved Satellite Parameters

AJISAI	RS-07
METEOR2-13	RS-10/11
METEOR2-14	SALYUT-7
METEOR2-15	METEOR2-18
METEOR2-16	
METEOR2-17	
METEOR3-1	
METEOR3-2	
MIR	
NOAA-10	
NOAA-11	
NOAA-6	
NOAA-9	
OSCAR-10	
OSCAR-11	
OSCAR-12	
OSCAR-13	
RS-05	

Fig. 10:
 An overview of the
 22 satellite parameters
 sofar programmed

verted to morse telegraphy tones and, of course, displays the plain text for comparison purposes as well. Furthermore, complete files can be converted to telegraphy output.

4. RESUME

After 18 months of experience with this program, the author can only report in positive terms about it. In the course of time, this program has evolved enormously in the light of experience. Program errors, which can always be expected to be present in a new release, have now been eliminated. This software has not been developed by a commercial programmer but by an amateur for amateurs. A great deal of trouble and time

has been invested in the development of this program which could not be justified if it were a purely commercial venture.

Finally, it must be re-emphasized great care which was taken by Wolfgang in order to make the program "watertight". Even deliberately false inputs do not lead to system breakdowns; on the contrary, either the program remains stubbornly awaiting the correct input syntax or it hands out distinct error announcements.

In one of the versatile instructional guides which are on the program diskette, the user can find exhaustive hints and tips right down to the plug pin-outs for converter connections. The AFU-program is so arranged that it can be easily used by amateurs who are relative beginners to computer work. This is facilitated by the use of graphic user screens engaged by a screen pointing device (Mouse).



Ralph Berres, DF 6 WU

Vision/Sound Combiner for AM-ATV Transmitter

The DJ 4 LB, 70 cm-band ATV Transmitter appeared to be very popular at large and so the concept was adopted by the local regional amateur radio club. After constructing the transmitter, it became clear that some details did not, in fact, meet current requirements. It is the author's opinion, that the simple RC amplifier used to combine vision and sound signals at 36 MHz could be the cause of intermodulation products. In addition, a better solution for the adjustment of power output was required. It was for these reasons

that a new module was developed which may be seen in the photograph of fig. 1.

1. CIRCUIT DESCRIPTION

The circuit schematic of fig. 2 shows that the isolation of vision and sound signals is assured by the provision of two separate input stages

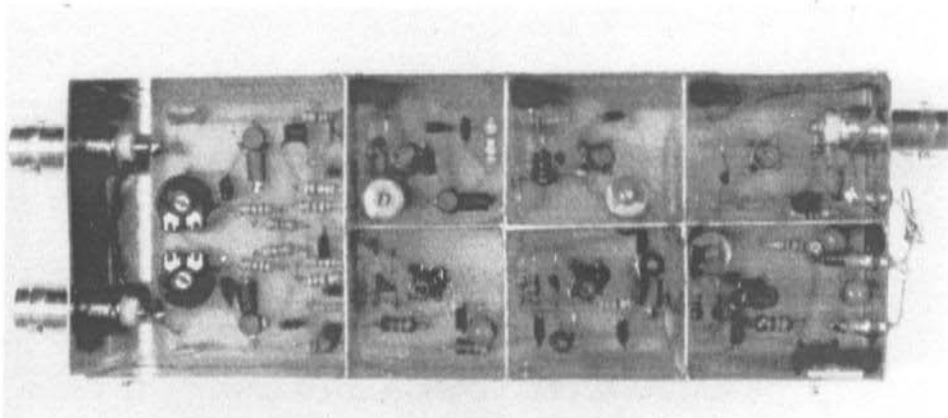

Fig. 1: Specimen of vision/sound module



each equipped with a dual-gate MOSFET type BF 900. Both operate with the source and gate 1 at a bias of 3.9 V in order to increase the gain control-range of the stage. The amplification adjustment is carried out in each stage by the 10 k Ω preset resistors which vary the voltage on gate 2. The input impedance is about 50 Ω .

Both input transistors work into a band-pass filter which carries both vision and sound signals. Two more similar band-pass filters follow with a stage of amplification between them. The penultimate stage, a BF 900 MOSFET, also works with a raised source voltage because at this stage the greatest gain variation is required. This is effected by the preset pot'meter controlling the voltage on gate 2 which controls, in turn, the transmit power output. The final transistor, a BF 199, is an emitter-follower which matches the last band-pass filter to the 50 Ω output.

All the band-pass filters are slightly over-critically coupled and so dimensioned that there is a 7 MHz band-pass between - 0.5 dB points and a maximal ripple of some 0.5 dB.

2. CONSTRUCTION

A printed circuit board has been developed for this project which fits into a 139 x 53 x 30 mm tinplate box. Fig. 3 shows the component layout for the board which is designated DF 6 WU 002.

When equipping this double-sided board, a ferrite bead is slipped over the drain lead of each BF 900 before mounting in position. This is to prevent the device from spurious oscillations in the GHz region. The top side of the board is the ground plane, all component holes which do not carry ground leads must be lightly counter-sunk on the ground plane side to prevent inadvertent contact with ground.

The inductors are wound on proprietary coil formers of 5 mm diameter with a suitable core for the frequency. The former is wound with 10 to 16 turns of 0.5 mm CuL, the exact number of turns depending upon the selected core material. The

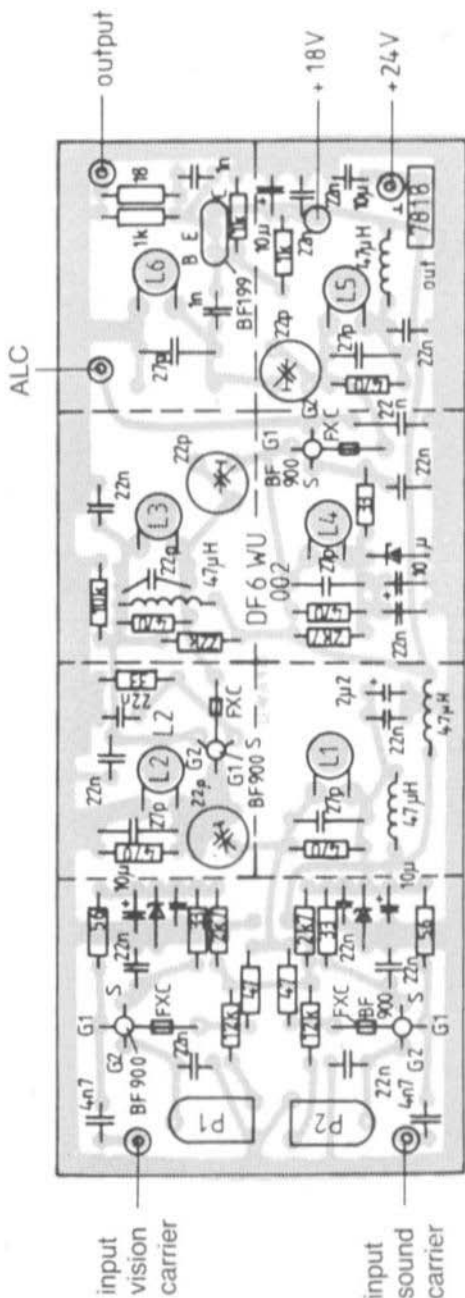

Fig. 3: Component layout of unit showing screen walls

inductance should then amount to some 680 nH and be tuned to a frequency of 40 MHz. As shown in the photograph of figure 1 of a specimen construction, the primary and secondary of each transformer are separated by a screen wall which prohibits magnetic coupling. The coupling is effected by means of a trimmer connecting the hot ends of the two windings.

All DC connections are brought in via feed-through capacitors (approx. 1 nF) and carefully decoupled. The 47 μ H RFCs are no luxury items that can be dispensed with!

The supply voltage is 24 V which is internally stabilized with a 7818 at 18 V. This unusually high voltage is necessary due to the high linearity requirements. If the module must be supplied by 12 V, the three zener diodes must be replaced by wire bridges and the 7818 dispensed with. It should, however, be mentioned that the amplification adjustment range and the intermodulation characteristics will be diminished.

After equipping the board and installing it in the tin-plate housing, the tin-plate screening walls together with the three BNC, or other HF sockets, are soldered in.

Finally, a 12 k Ω resistor is soldered in series with the + 18 V feed-thro' capacitor and a 22 nF capacitor from the source of the final BF 900 to the screening wall. This must use as little connecting wire as possible, otherwise the whole stage will self-oscillate.

3. TUNING ADJUSTMENT

A multi-meter and a sweep generator test set-up centred on a frequency of 38.9 MHz is absolutely necessary to tune this module. The procedure is as follows:—

```

Y-Input:      Timebase:      Trigger:
100 mV/div   500 us/div      AUTO
DC 1:1                               INT DC
                                           POS
  
```

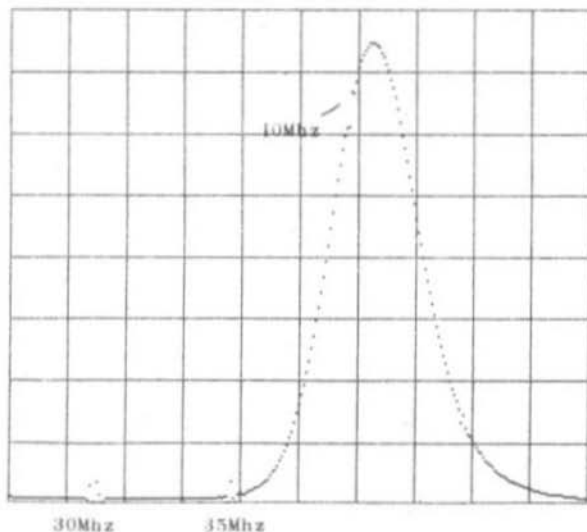

Fig. 4:
Response curve following initial tuning procedure (coupling trimmers minimum with input at 500 mV)



Y-Input: Timebase: Trigger:
 100 mV/div 500 us/div AUTO
 DC 1:1 INT DC
 POS

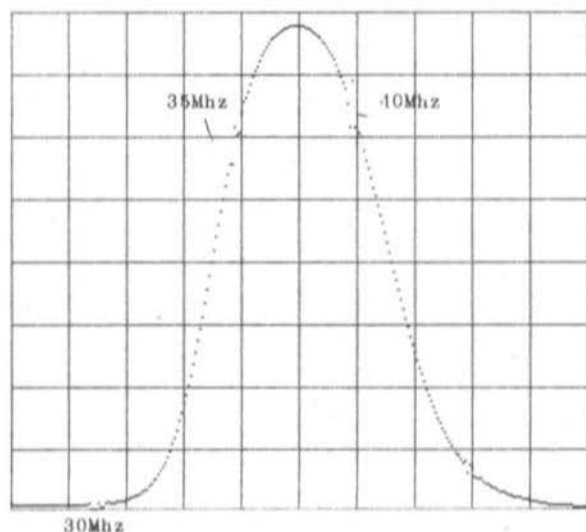

Fig. 5:
 Response after coupling trimmers were advanced equally. Maximum gain results and bandwidth somewhat wider (input voltage: 16 mV)

Y-Input: Timebase: Trigger:
 100 mV/div 500 us/div AUTO
 DC 1:1 INT DC
 POS

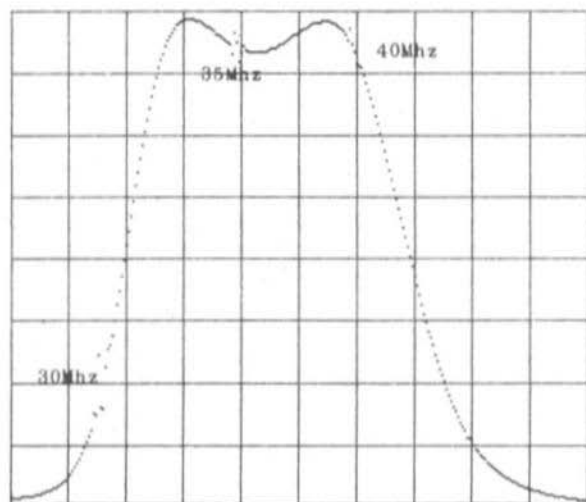

Fig. 6:
 Final tuning procedure produces this characteristic. The centre point is shifted 0.5 MHz higher by adjusting the inductor cores (input voltage: 16 mV)



Turn the three pre-set pot'meters to maximum i.e. extreme clockwise. Check the voltage across the zener diodes (3.9 V). Check the stabilized 18 V. Measure the potential difference (PD) across all source resistors – they must be between 0.2 V and 0.3 V. The BF 199 emitter voltage should be about 9 V.

The three coupling trimmers should be set to minimum capacitance. The sweep generator should then be connected to both inputs. The diode probe is connected to the hot end of L1 and the generator adjusted for a trace on the oscilloscope.

Using the test probe, the six inductors are adjusted for maximum voltage. If the level is too low to detect the voltage, adjust the three coupling capacitors to an increased value and try again. When all the inductors have been tuned to maximum, the band-pass characteristic should look like that of **fig. 4**.

The output is now terminated with 50 Ω , preferably using a 50 Ω detector such as that described by DJ 4 GC. The output voltage from the sweep generator is adjusted to some 20 mV and all three coupling capacitors are advanced by the same amount until the pass band is wider and looks like that of **fig. 5**.

The gain increases dramatically and the output from the generator must be adjusted to prevent saturation from distorting the trace.

By a further increase of the coupling capacitors, again all by the same amount, the curve begins to flatten and then dip slightly in the middle. The circuit is correctly tuned when the bandpass between 0.5 dB points is 7 MHz and the humps are not more than 0.5 dB above centre value. The trace then looks like that of **fig. 6**.

Finally, the 0.5 dB turn-over frequencies are adjusted to 33.3 and 40.3 MHz by turning the coil cores, by the same amount, in or out. The overall gain should now be about 20 dB. All coupling trimmers and all inductor cores should be seen to be identically adjusted, otherwise the tuning is totally in error.

4. ADJUSTING THE TRIMMERS

After this module has been installed in the ATV transmitter and made "RF-tight" the AF and VIDEO preset pot'meters are then turned provisionally fully anti-clockwise. The frontal panel mounted gain control potentiometer is turned fully clockwise.

The picture carrier is then switched on and modulated with BAS. Increase the VIDEO preset until the synchronizing pulses are just not compressed. If the signal has to be attenuated by more than 10 dB by this preset then a fixed attenuation pad must be inserted at the signal input to avoid overloading the FET stage thus giving rise to IM distortion.

The vision-carrier power is noted and the vision signal switched off. The audio output is then adjusted with the AUDIO preset until it is 13 dB lower than that noted for the vision. An input pad may also be necessary here to reduce the input level to the FET amplifier.

A specimen module, following the implementation of the above line-up procedure had a 3rd-order IM level of - 60 dB rel carrier at an output level of 100 mV.

Although this unit already has a very good selective filter it should be followed by a good side-band filter in order to reject residual spurious products.

The following UHF mixer module (DJ 1 JZ 002) was equipped by the author with dual-gate MOSFETs (BF 907) in the first two stages. The sensitivity was then so high that 100 mV drive was too much and the common gain potentiometer had to be turned down to obtain a decent monitor picture.



Dr. Eng. Jochen Jirmann, DB 1 NV

A Spectrum Analyser for the Radio Amateur Part 3a: Construction and PCBs

3. THE CRYSTAL FILTER DB 1 NV 008

The description of the crystal filter can be kept to a minimum here since the characteristics for a crystal filter, suitable for a spectrum analyser, have already received an airing in edition 3/87.

The basic circuit of the crystal filter was taken from this article, viz.: four single crystal-filter stages in cascade to achieve the necessary selectivity. Originally, the filter bandwidth was determined by switching attenuator pads into the individual filter by means of switching diodes. The one presented here in **fig. 9**, on the other hand, has a continuously adjustable bandwidth in the range 1.5 to 50 kHz.

To achieve this, the attenuator networks are made continuously variable with the use of PIN diodes. As the dynamic resistance of the BA 379 in the blocked condition is too low, two diodes have been used in series to achieve the necessary isolation.

The crystal filter is fitted with a diode switch which enables the filter unit to be completely bypassed.

3.1. Construction and Alignment of Module DB 1 NV 008

Before the construction of the filter module is contemplated, the question of the procurement of suitable crystals must be considered. Oscillator crystals can be ruled out, in every case, owing to their many spurious responses. The safest, and cheapest, way is to purchase a couple of old 10.7 MHz crystal filters such as, for example, the Telefunken QF 10.7 - 30. These are taken apart and suitable quartets of identical-frequency crystals selected – the characteristics of suitable crystals have already been described.

Following these preparations, the printed circuit board DB 1 NV 008 is soldered into a tin-plate housing and equipped according to the component layout plan of **fig. 10**. Of particular importance is the screening wall between the filter proper and the switch selector section. If this screen is omitted, the selectivity will be severely compromised. A completed example of DB 1 NV 008 is shown in the photograph of **figure 11**.

All the trimmer capacitors are first of all set to their mid positions. The supply voltage (15 V) is connected and the unit input connected to a suitable 10.7 MHz sweep generator. The input

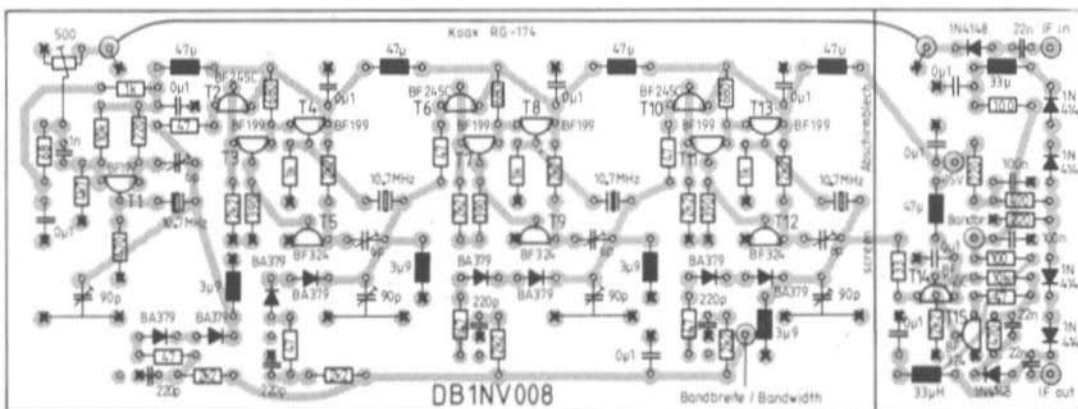

Fig. 10: Crystal-filter PCB component layout plan

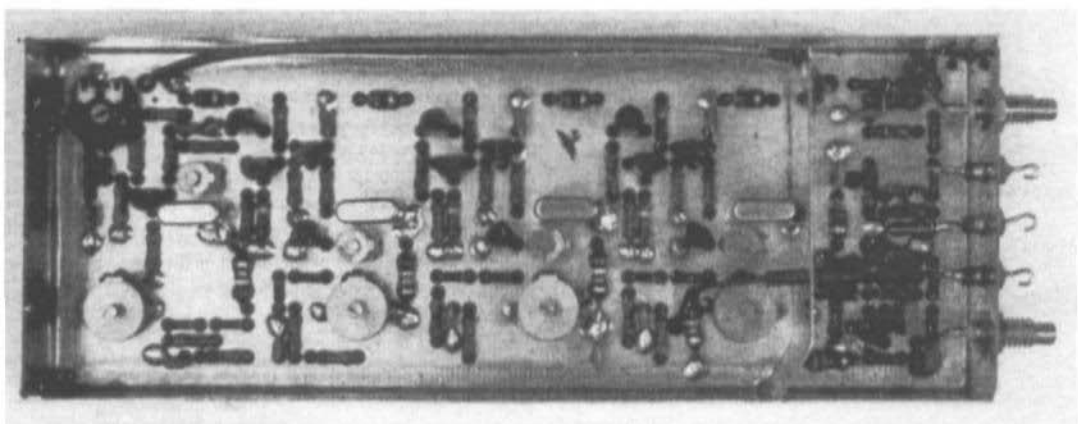

Fig. 11: A completed crystal-filter module

Finally, the insertion loss of the filter is checked. With the 500 Ω potentiometer on 1 (0 dB) the response should be the same, i.e. the height of the response curve should not alter when switching the filter in or out.

3.2. Component list for DB 1 NV 008

Semiconductors

D1...D6:	1 N 4148 or equiv.
D7...D14:	BA 379 or successor RA 389

all NPN transistors:	BF 199
all PNP transistors:	BF 324
all FETs:	BF 245A

Capacitors:

4 foil trimmers: 90 pF, 3-legged, grid 5 x 10 mm, VALVO

4 foil trimmers: 6 pF, 2-legged, grid 5 mm, VALVO

all other capacitors: ceramic, grid 2.5 mm

Inductors:

4 miniature RFCs: 3.9 μ H, SIEMENS MCC, grid 7.5 mm



2 miniature RFCs: 33 μ H, SIEMENS MCC,
grid 7.5 mm

5 miniature RFCs: 47 μ H, SIEMENS MCC,
grid 7.5 mm

Resistors:

1 preset: 500 Ω , horiz., grid 5 x 10 mm

all other resistors: 1/8 W, series 0204 or 0207

Miscellaneous:

1 PCB: DB 1 NV 008

1 tin-plate box: 54 x 148 x 30 mm

4 filter crystals: 10.7 MHz

3 feed-through capacitors: 2.2 nF (uncritical)

2 miniature coax sockets: Subclac (SMC, as in
prototype)

coaxial cable: RG 174/U or thinner, 12 cm approx.

4. SWEEP GENERATOR AND VIDEO FILTER (DB 1 NV 009)

This module, which has not previously been mentioned, fulfils the following functions:

- Generates the sweep oscillator saw-tooth wave for the scan.
- Generates the display horizontal deflection signal.
- Filters the video signal with a selectable limit frequency.

The circuit schematic for the module DB 1 NV 009 is presented in **fig. 12**.

The saw-tooth generator comprises I1 (NE 555) and T1 together with its accompanying passive components. As the functioning of the timer (IC NE 555) is well known, only the peculiarities of this particular circuit will be mentioned. The period-determining capacitor at I1 pin 7 is charged linearly by a constant current source using T1 in a bootstrap circuit. This charging current may be varied with the "sweep frequency" pot' meter P3. When the emitter of T1 has reached the upper trigger threshold of the NE 555, the capacitor discharges instantly via pin 7 of I1. I1 is flipped into the charge condition following a delay caused by a hold-off network between pins

2 and 6. This gives the frequency-control-loop time to reach the start frequency again.

The ever present signal at pin 3 of the NE 555 is high on the sweep display-trace transit and low upon its return. It is combined in I2 with the saw-tooth waveform and that is used as the horizontal scan deflection signal. The reason for this arrangement is as follows: Normally, the display unit's trace is blanked during the return scan. Not all oscilloscopes, however, are fitted with a DC-coupled blanking facility. The return scan is therefore simply deflected into the left-hand CRT edge thereby making it invisible.

The frequency coverage of the saw-tooth generator can, moreover, be decreased by a factor of 15 by taking pin 1 of the module to ground, in order to accommodate the requirements of an XY-recorder.

The saw-tooth signal is level-changed in I2 and is passed via a stepped divider for the control of the scan width. The construction of this resistive divider chain is identical with the one previously published. The signal is buffered with I3 and is then fed to either the first, or the second oscillator according to the width selected. At scan widths of under 500 kHz/cm the range switch is arranged to energise a relay which diverts the scan signal to the second local oscillator. At the same time the time constants of the frequency control loop are switched to "slow" by means of a reed relay.

The scan saw-tooth signal is then inverted with other operational amplifiers and the voltage added to the fine adjustment control before being taken to the 2nd LO's varicap diode. Linearising the tuning characteristics of the varicap diode was found to be unnecessary when the applied tuning voltage was in the range 5 to 10 V.

If the image reception range, from 1000 to 1500 MHz, is to be used, the 2nd LO's scan direction must be reversed. This is carried out by breaking the connection between pt 15 and pt 13 and the latter connected to pt 18 instead. This is best done with a switch, which at the same time, shifts the indication range of the frequency counter and also switches in an appropriate high/low-pass filter combination before the 1st. mixer, as a preselector.

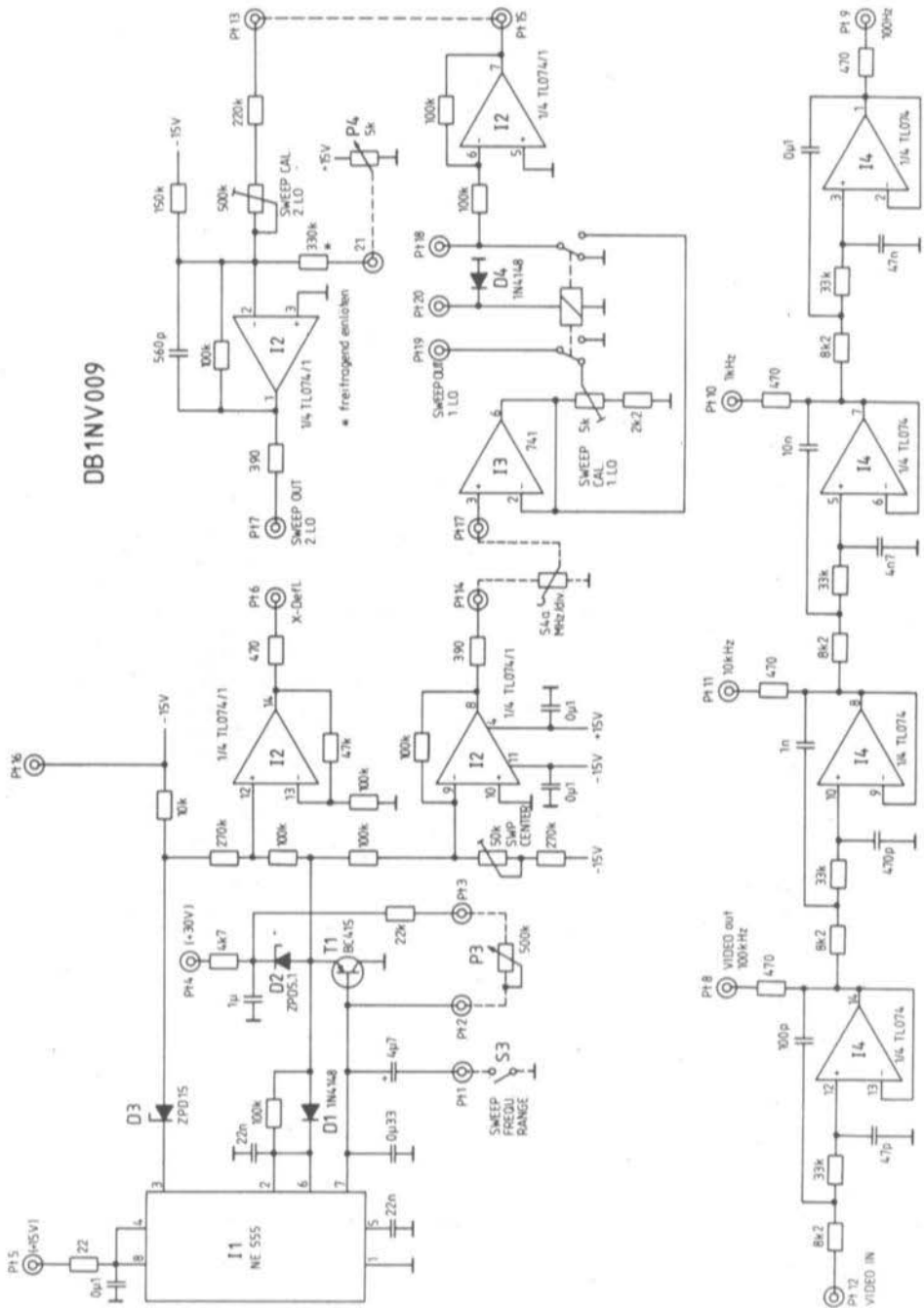

Fig. 12: Sweep-control and video-filter DB 1 NV 009

* wire-in free

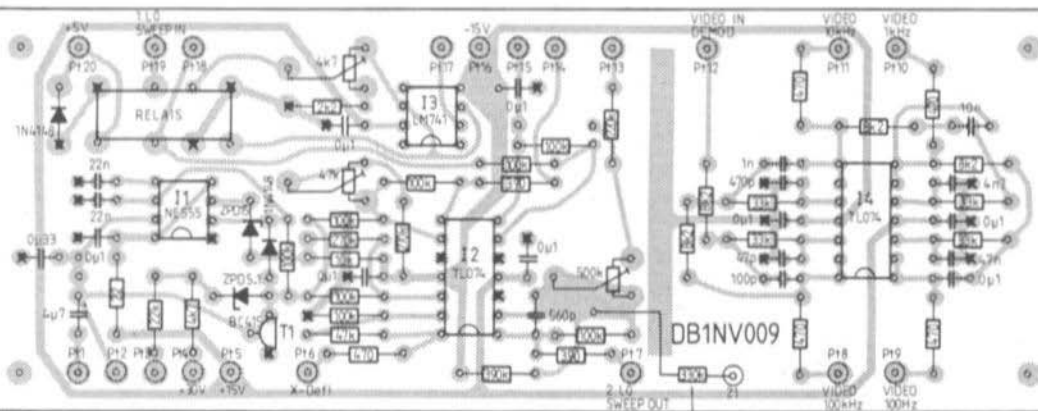

Fig. 13: Component layout plan for PCB DB 1 NV 009

wire-in free

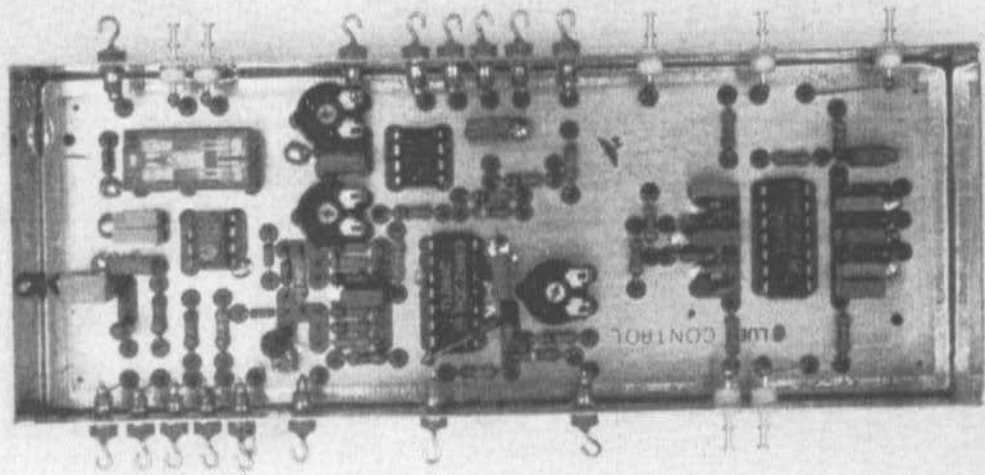

Fig. 14: A completed sweep-control module

The video filter is fully independent of the other circuits on the board. It consists of four cascade, 2nd-order, Butterworth, low-pass filters with limit frequencies of 100 kHz, 10 kHz, 1 kHz and 100 Hz. In order that the 100 kHz filter section is viable, it uses a TL074 (14) operational amplifier or similar type. A point to be observed here is that the filter capacitors must be high-grade types; e.g. type-I-ceramic, styroflex (KS) or FKC/MKS types all having a maximum tolerance of 10 %. Ceramic typ-II-decoupling capacitors; e.g. Sibatit 50000 are absolutely unsuitable for this purpose!

4.1. Construction and Alignment of DB 1 NV 009

The printed circuit board DB 1 NV 009 is equipped in accordance with the layout plan of fig. 13. A screening wall, such as those in the other modules, is not necessary here. If, for appearance sake, the PCB is to be enclosed, it should be soldered into its housing before the components are mounted. There are no particular problems concerning the choice of components, apart that is, from the already mentioned filter capacitors.

Setting-up is assisted by the provisional placement of a 500 k Ω pot'meter (P3) between PCB pins 2 and 3. The supply voltages of ± 15 V and + 30 V are then connected to PCB pins 5, 16 and 5 respectively.

It should now be possible to measure a saw-tooth waveform at the emitter of T1 with an oscilloscope – it should have an amplitude of around 10 V. Its frequency can be varied with the external pot'meter. A 14 V_{pp} square-wave signal should now be measured at I1 pin 3. The sum of both these waveforms can now be measured at the PCB pin 6 (X-OUTPUT). At PCB pin 14 this waveform appears symmetrical about ground potential and inverted. The exact disposition about the null point can be made with the preset "SWEEP CENTER".

When PCB pins 14 and 17 are now connected together, the same saw-tooth waveform is present. It is present at pins 18 and 19 but depending upon the position of the relay. The same signal appears at pin 15 but inverted relative to that at pin 18. After connecting pins 13 and 15, the sweep signal for the 2nd local oscillator can be controlled at pin 7. The exact adjustment of the presets "SWEEP CAL" (sweep widths of 1st and 2nd LOs) are carried out when the spectrum analyser has been assembled, using a spectrum generator.

The low-pass filter doesn't need any alignment, it could, however, be checked with a function generator to check its frequency response. A square-wave generator could be used to check its impulse characteristics. Overshoot would indicate false values for resistive or capacitive components. A completed example of module DB 1 NV 009 is to be seen in the photograph of fig. 14.

4.2. Component List for DB 1 NV 009

Semiconductors

I1: NE 555 or ICM 7555 (CMOS version)
 I2, I4: TL 074, TL 084 (Texas)
 I3: LM 741
 T1: BC 415, BC 309
 D1, D4: 1 N 4148
 D2: ZPD 5.1
 D3: ZPD 15

Capacitors

under 1 nF: ceramic, grid 2.5 mm
 over 1 nF: foil, grid 5 mm
 1 electrolytic: 4.7 μ F

Resistors

1 preset: 4.7 k horiz. grid 5 x 10 mm
 1 preset: 47 k horiz. grid 5 x 10 mm
 1 preset: 470 k horiz. grid 5 x 10 mm
 all resistors: series 0207

Miscellaneous

PCB: DB 1 NV 009
 relay: 2-pole c/o, say FUJITSU D006/020E
 or ITT (RZ relays)
 or SIEMENS – all pin compatible.

5. MODULE INTERCONNECTIONS AND CHASSIS WIRING

Following the alignment and testing of the four modules, the interconnecting wiring, according to the diagram of fig. 15, can commence. In addition to the four modules described, three highly, stable supplies of ± 15 V and + 30 V will have to be provided. Also, a digital-voltmeter module for the frequency indicator and diverse potentiometers and switches. No details will be given here for these items as they will be largely determined by the individual mechanical construction and from the space available. The following remarks will explain a few circuit peculiarities:

- All conductors marked "coax" use RG 174, or similar, coaxial cable. Some low-frequency lines also use coax. where they are subject to interference fields.
- The resistances around S5a, for the display width selection, are all 1 % metal-film types as the accuracy of the frequency readout on the trace is dependent upon these resistors.
- In the diagram of fig. 15, the IF bandwidth and the video bandwidth are controlled with a common switch, S1. The switch S2 allows only the global switching of the video filter in or out of circuit. These switches can, of course, be separated.



– The tuning pot'meters for both the 1st and the 2nd local oscillators (P5 and P4 resp., fig. 15) are conveniently 10 and 3 turn, respectively, wire-wound pot'meters.

The final setting-up is carried out with the following steps:

The display oscilloscope is connected and the length of the frequency axis trace adjusted to about 10.5 cm (i.e. just over full width),

The highest IF bandwidth and amplification (P1) together with the highest display width, 0 - 500 MHz (S4, Full Scan) is selected. Supply a 100 MHz signal, adjustable in the range - 40 dBm to - 100 dBm, to the input of the analy.

The Y-gain and Y-position are iterated so that the 100 MHz signal just touches the upper line of the top calibration box, i.e. - 40 dBm. Attenuating the input signal in 10 dB steps should result in the displayed signal hitting the top of the next lower box. Deviations, within say ± 2 dB from this requirement, are a permissible consequence of

the component tolerances of the TDA 1576 logarithmic demodulator circuit.

A spectrum generator is then used to calibrate the sweep width using 50 MHz spaced input signals. The sweep width of the 1st LO is adjusted with the "1st LO SWEEP CAL." control so that a spectral line appears at every 1 cm graticule line. Preset R1, in the chassis wiring, will enable the 0 graticule line to coincide exactly with the zero reference of the analyser, i.e. the frequency of the 1st LO corresponds with the 1st IF.

The sweep width is then switched to 200 kHz/cm and the fine frequency control of the 2nd LO (P4) set to the mid-way position. The IF bandwidth will thereby be reduced to some 20 kHz. The spectrum generator is set to 200 kHz spaced signals and the 2nd LO aligned, in a similar fashion, with preset "2nd LO SWEEP CAL" in the sweep control module.

After the remaining operating functions (such as the PLL) have been checked, the setting-up procedure for the analyser is completed.

GF 151 GF 401 GF 404 GF 411 GF 23-3

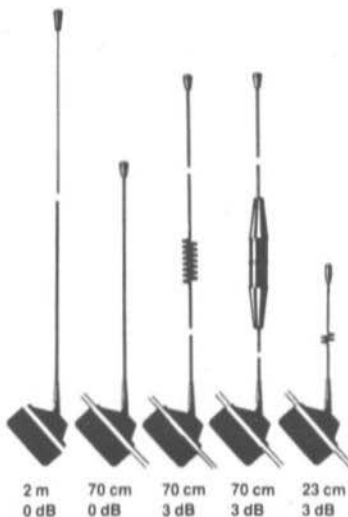

GlassFix[®] **Antennas**

A small selection of our wide range of mobile antennas

- * Require no holes in your car
- * Transmit through glass
- * No ground plane required
- * Performance equal to roof mounted antennas
- * Can be removed leaving no trace of the installation
- * Re-installation kit available

Model	GF 151	GF 401	GF 404	GF 411	GF 23-3
Type	1/2	1/2	collinear	collinear	collinear
Frequency	138 - 175 MHz	430 - 470 MHz	430 - 470 MHz	430 - 470 MHz	1240 - 1300 MHz
Gain	0 dB	0 dB	3 dB	3 dB	3 dB
max. power	25 W	25 W	25 W	25 W	25 W
Cable	4 m RG 58	4 m RG 58	4 m RG 58	4 m RG 58	4 m RG 58
Length	85 cm	25 cm	66 cm	66 cm	17.5 cm
Art.No.	0163	0164	0165	0168	0166
Price	DM 98.00	DM 83.00	DM 95.00	DM 99.00	DM 110.00



Jürgen Dahms, DC Ø DA

The "microline 3" Transverter System

The Break-through in 10 GHz Experimental Communications

Part 2

3. RECEIVE MIXER XRM-1

The receive-mixer printed circuit board uses double-sided copper clad teflon. The PCB has the dimensions 72 x 108, is pre-drilled and galvanically silver-coated and fits into a 74 x 111 x 30 mm proprietary tin-plate box. The teflon PCB material goes under the name DI-CLAD, has a dielectric constant of 2.5 and is only 0.79 mm thick, the copper cladding being 35 microns.

3.1. Circuit Details

The XRM-1 (fig. 7) contains a low-noise receive mixer together with a GaAs-FET x4-multiplier having a power output stage which delivers power at the LO frequency of 10224 MHz.

The input signal is amplified in two SHF stages before being presented to the GaAs-FET mixer (T3) via a cavity resonator. The mixer down-converts the 10 GHz signal into the 2 m amateur band. The GaAs-FET x4-multiplier (T4) is driven by the 2556 MHz signal from the XLO-1 at a power of ca. 5 to 10 mW. Following filtering in a

cavity resonator, it is fed to the GaAs-FET transmit output stage. About 3 mW of LO power goes to feed the receiver mixer via the etched directional coupler. The remaining power, of at least 5 mW, goes to supply the transmit mixer XTM-1.

As for the local oscillator module XLO-1, step by step details are supplied for all the necessary stages of the construction and where necessary, very full explanations are given. Indeed, many an experienced SHF constructor may well feel a little patronized by some of the explanations.

3.2. Installation of the Board XRM-1 in the Tin-Plate Housing and Component Mounting

1. Put the side walls into one of the covers and adjust for correct fit.
2. Temporarily, spot solder the walls together at the top and bottom corners.
3. Snip off the fixing lugs of the BNC-sockets and file off the residue. Feed the BNC centre connectors into the corresponding drillings, align and then solder the BNC mounting flange to the housing frame all the way around its periphery.

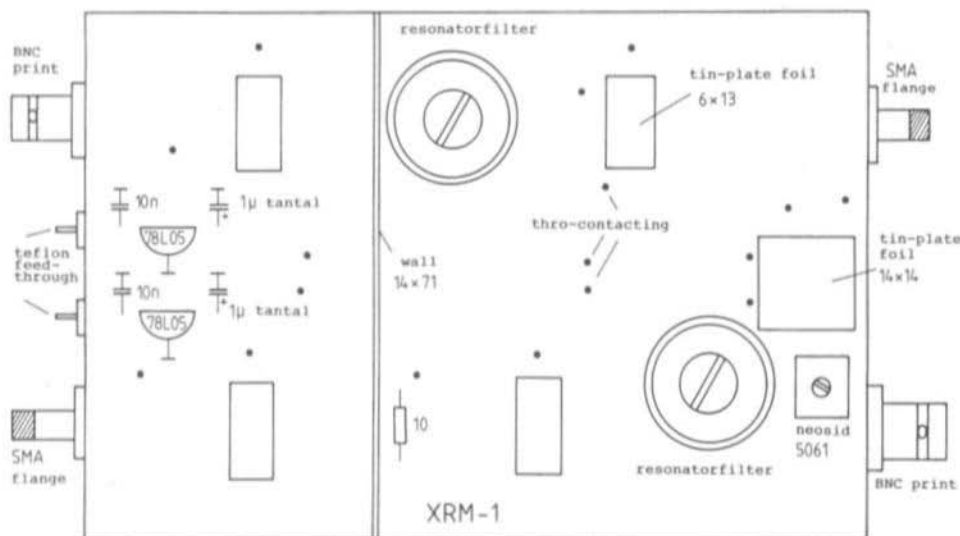

Fig. 8: Component lay-out showing the placement of filters, foils and through-tin-contacting from the XRM-1's ground-plane side

4. Snip off 3 mm from the centre connector of the SMA flange socket and remove the small teflon collar with a sharp scalpel. Feed the connector through into the drilling provided, align, and then solder the flange all the way around to the housing frame.

5. By judicious filing, fit the teflon PCB into the mounting frame.

6. Solder in the coupling loops for the both resonator filters according to the component layout plans (figs 8 and 9), and in detail, fig. 10. Pay particular attention to the correct orientation of the loop — both loop grounds should be adjacent to one-another.

The following procedure has been found to be the most expeditious: —

A length of 0.5 mm dia. silvered wire is bent into a "U" form over a 1.5 mm drill. One side is snipped

off as the loop is being held against the drill as the snips are transverse to the plane of the drill. The long side of the loop is passed through the appropriate hole from the ground-plane of the PCB. As the loop end is being held against the surface of the board with a finger, the board is turned over and the long end of the loop soldered on to the correct PCB track and the remainder snipped off as close as possible.

The drill can now be carefully withdrawn, the loop adjusted to an exactly upright position and with a fine pointed soldering iron bit, the other end is soldered to the ground-plane. The mound of solder should fully encompass the wire junction to the board but should be as small as possible, consistent with a good electrical joint.

7. The board is then laid with its track-side face down on to a plane surface. The two resonator filters are then positioned according to the PCB

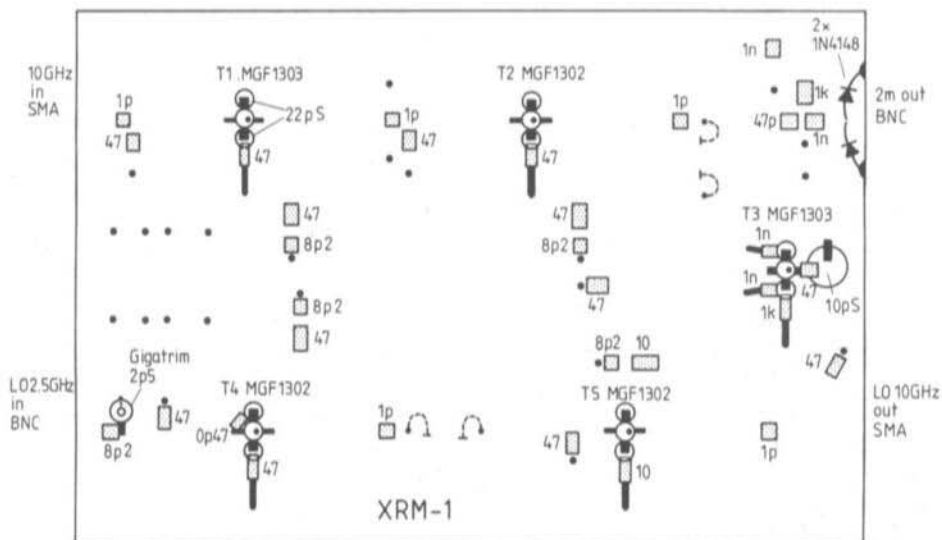

Fig. 9: XRM-1 lay-out plan from the microstrip-line side

layout markings and using a piece of wood to maintain the component in firm contact with the surface, they are soldered all the way around their peripheries to the ground-plane (fig. 11). Care should be taken to see that no solder flows through into the cavity interior.

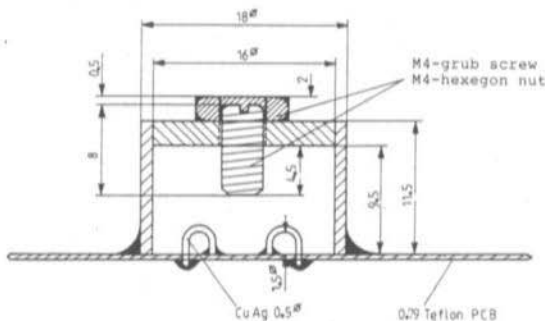

Fig. 10:
Dimensions of the resonator filter
showing tuning screw and 10 GHz
coupling loops

8.

A strip of 0.5 mm tin-plate is then soldered, all the way around, over the holes drilled to receive T3. This will retain the source de-coupling capacitor and the 10 pF chip capacitor in the drain lead of T3 (see fig. 8).

9.

The 18 through-board contacts (fig. 8) for the chip capacitors and resistors are carried out with 0.5 mm dia. wire.

10.

It can occur that the PCB becomes a little distorted following this quite intensive soldering. It can be bent back into shape with careful and fro movements.

11.

The track side of the board is now offered up to the tin-plate wall frame where it will rest on the centre spigots of the four HF connectors. The PCB is then spot soldered, ground-plane side to wall, at several points. The position of the board is then inspected carefully before it is finally



soldered in to the frame – all the way around its periphery.

12.

The 0.5 mm thick, ready-cut, tin-plate, dividing wall is then laid along the marked transverse line (fig. 8) on the PCB's ground-plane side and spot soldered at a few points. It is then adjusted for correctness of position and soldered all the way along the wall (opposite side to the resonator) to the ground-plane's surface. This wall is not actually for screening purposes but serves as a stiffener for the whole module.

13.

The stiffening wall is finally soldered to the sides of the frame.

14.

If the soldering of the PCB to the frame has gone according to plan, it should have been set in about 15 mm deep on the ground-plane side. This leaves just about 13 mm for the track side to the top edge of the frame. This should be checked at this stage!

15.

The centre pin and the two fixing tabs on the Neosid coil are snipped off and the inductor set into the board from the ground-plane side. The coil connecting pins are then soldered to the track and the screening can be soldered, on two opposite sides, to the ground-plane.

16.

The remaining components (2 voltage regulators together with de-coupling capacitors and 10 Ω resistor) are then soldered in accordance with the layout plan of fig. 8. Observe the correct polarity of the voltage regulators.

With this, the work on the ground-plane side of the board has been completed.

17.

The teflon feed-through connectors for the supply potentials of both multiplier and receive mixer are then fed through the holes provided in the walls and soldered to the corresponding tracks.

18.

Solder the connecting leads of the four input and output connector sockets to their respective tracks.

19.

Solder in the plate de-coupling capacitors.

For technical production reasons, much smaller capacitors had to be used than those for which

the hole was provided.

First of all, the metal strip soldered on the ground-plane, is carefully tinned on the track side (preferably before being soldered in!). The 22 pF plate capacitor is then carefully placed, using fine tweezers, right up against the edge of the hole. The whole module is then raised and a fine tipped soldering iron is used to bring heat to bear on the other side of the strip, directly underneath the chip capacitor. After a while, the solder will flow and the chip capacitor is safely soldered to the tin-plate.

Check with an ohmmeter that no solder has flowed across to the upper surface.

Finally, the larger 10 pF plate capacitors are soldered in using the same procedure.

20.

Solder the etched HFC in T4's input to the housing.

21.

Solder in the 5 GaAs-FETs. The drain connections are marked with a coloured spot. The various types of GaAs-FET can be seen from the printing as well as from the colours on the gate side. They can be differentiated from each other as follows:—

MGF 1302: Black spot on the gate side or black printing (e.g. **AB**)

MGF 1303: Green spot on the gate side or red letters (e.g. **Bd**)

The chamfered connector on a Mitsubishi device is always the gate!

All connectors are cut to a length of 2 mm. Retain the snipped off source leads for other (later) soldering work.

The GaAs-FET is carefully positioned, using tweezers, centrally between the source de-coupling capacitor and the strip-circuit tracks. The gate and the drain connections are soldered first to the tracks. The source lead is then carefully bent, with a small screwdriver, until it touches the top surface of the chip capacitor. The lead is then carefully soldered to the chip capacitor, the solder flowing right up to the ceramic body of the GaAs-FET.

22.

Solder in all the SMD resistors according to the

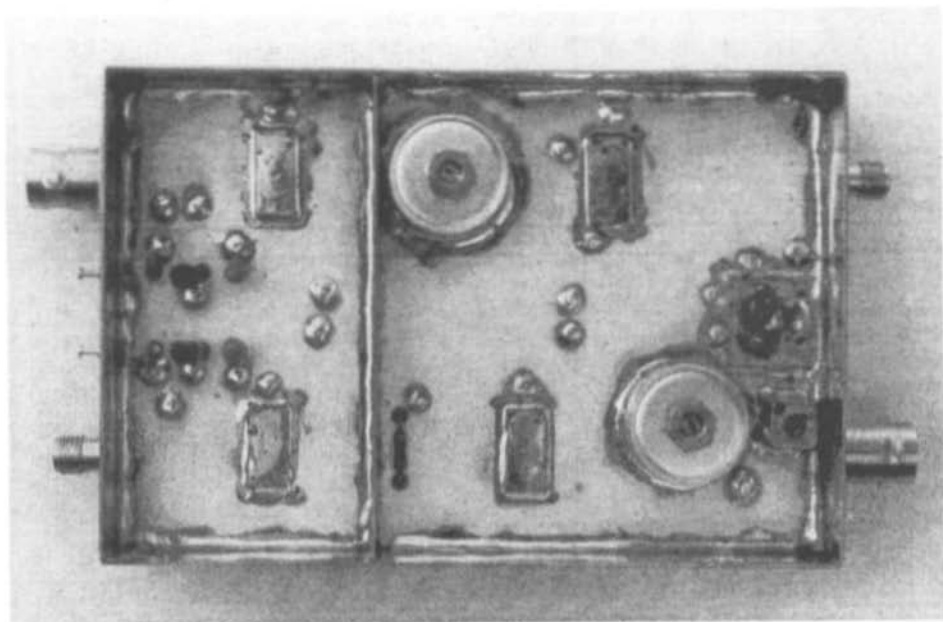

Fig. 11: Receive mixer XRM-1 from the ground-plane side

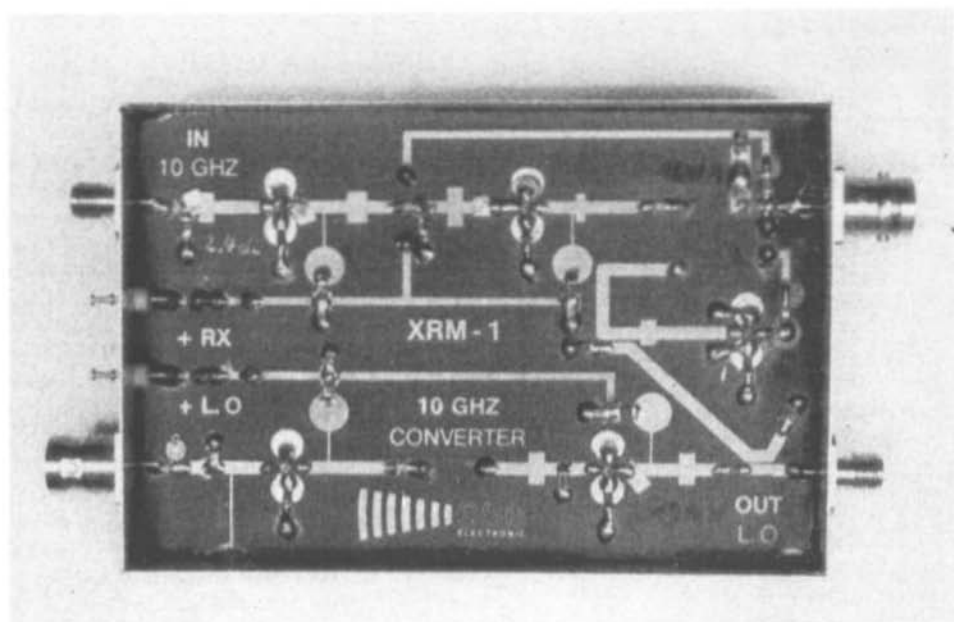

Fig. 12: Receive mixer XRM-1 from the microstrip-line side



component layout plan of fig. 9. The cut-off portions of the source connectors are now used to extend the resistor connectors to the ground through-connectors.

23.

Extend the drain lead of the receive mixer (T3), by means of a wire bridge, across to the 10 pF decoupling capacitor and solder.

24.

Solder in all the SMD capacitors according to the component layout plan of fig. 9.

25.

Solder in the sub-miniature 2.5 pF ceramic trimmer in the x4 multiplier's (T4) input. The side with the red spot must be connected to ground.

26.

The two reverse-connected shunt protection diodes (1 N 4148) across the output socket of the receive mixer (T3) must be soldered with the shortest possible connecting leads. Watch the polarities! The ground connectors should be carried out following the soldering together of the frame.

27.

Carefully check all solder connections to the SMD components, as well as the GaAs-FETs, using a magnifying glass.

A completed XRM-1 module is shown in figures 11 and 12.

3.3. XRM-1 Components

- 1 x PCB XMR-1 (ready drilled and plated)
- 1 x Tin-plate box (proprietary) Nr 6 (74 x 111 x 30)
- 1 x Tin-plate 14 x 71 0.5 mm thick
- 1 x Tin-plate 14 x 14 0.5 mm thick
- 4 x Tin-plate 6 x 13 0.5 mm thick
- 1 x Carbon plastic foam (conductive) matting 72 x 108 x 6
- 2 x Resonator cavity, silvered, M4 screw-thread in top 18 mm ext. dia., 16 mm int. dia., height ext. 11.5 mm, int. 9.5 mm
- 2 x Grub screws (brass) M4, overall length 8 mm
- 2 x Flat (brass) M4 hexagon nuts, 2 mm thick
- 1 x Length silvered wire, 10 cm long, 0.5 mm dia.
- 1 x Trimming tool Johanson type 4192
- 1 x Neosid coil 5061

- 2 x Teflon feed-through connectors
- 2 x BNC PCB sockets
- 2 x SMA flange sockets
- 2 x Voltage regulators 78L05
- 1 x Sub-miniature ceramic trimmer Johanson 2.5 pF
- 2 x Diodes 1 N 4148
- 3 x MGF 1302
- 2 x MGF 1303
- 2 x 1 μ F/35 V tantalum
- 2 x 10 nF capacitors
- 1 x 10 Ω resistor
- 1 x Copper foil 10 x 20, 0.05 mm thick
- 10 x High Q plate capacitor 22 pF, 3.2 mm dia. 0.25 mm thick
- 1 x High Q plate capacitor 10 pF, 5 mm dia. 0.75 mm thick

16 chip capacitors:

- 1 x 0.47 pF
- 5 x 1 pF
- 5 x 8.2 pF
- 1 x 47 pF
- 4 x 1 nF

16 SMD resistors:

- 2 x 10 Ω
- 12 x 47 Ω
- 2 x 1 k Ω

3.4. Receive-Mixer Module XRM-1 Alignment

1.

Turn the M4 tuning screw of the filter resonator between the multiplier and the power amplifier so that the head of the grub screw is about 0.5 mm under the top edge of the M4 Hexagon nut. Then lightly tune the M4 nut to lock to the cavity top. The grub screw then protrudes into the cavity by some 4.5 mm (see fig. 10).

2.

Connect a suitable power meter (3)(4) to the output of the frequency multiplier and also the supply voltage to the appropriate teflon feed-thro' via a multimeter. A current of approximately 50 mA should flow.

Then connect the Local Oscillator Module XLO-1 via a BNC cable, of uncritical length (ca. 10 - 25 cm), to the input of the multiplier. Adjust the ceramic trimmer at the multiplier (T4) input for maximum current (a rise of ca. 6 mA can be expected). Use the Johanson trimming tool 4192



or a suitably sharpened match stick or tooth pick. A watchmaker's screwdriver, even if it fits the slot, is not suitable owing to its large metal mass which causes de-tuning. The output power in the power meter should read between 3 and 5 mW.

3.

A tin-plate cover fitted with a carbon foam-plastic mat (72 x 108 x 6 mm) stuck to the inside, is then fitted to the track side of the frame/PCB assembly.

4.

Turn the assembly around and gently tweak the M4 tuning screw. There should now be an output power of at least 5 mW.

5.

Disconnect the power to the module for the next step. By soldering a copper foil of about 3 x 5 mm as close as possible to the drain of T5, the output power can be increased by a further 3 dB. This brings the output power to a final 10 mW. Only 5 mW oscillator power at 10.224 GHz is actually required to drive the transmit mixer module XTM-1.

6.

Following the successful alignment of the power amplifier, the power meter is removed and the SMA-connector terminated – either with a proprietary 50 Ω termination or with a ca. 10 cm length of SMA-cable with a loss as high as possible (e.g. RG 58 C/U).

7.

Tune the M4 tuning screw of the resonator filter between the second HF pre-amplifier and the mixer in the manner described in step 1.

8.

Connect a 144 MHz transceiver to the output of the receiver mixer and apply the supply voltage to the second teflon feed-through. The supply current should rise by ca. 32 mA. Tune the NEOSID coil for maximum noise in the 2-metre receiver.

9.

If there is no 10 GHz transponder signal in the region and no noise generator can be procured, then some other means must be found to optimise the receive section. Perhaps an harmonic-generator (see (7)).

The antenna cable, or the alignment aid, is applied to the first HF stage of the pre-amplifier

and after tuning-in the signal in the 2-metre receiver, proceed to align as described under step 4. Ensure that the cover is on the track side of the assembly before starting the alignment (see step 3).

10.

Turn the module over and remove the cover in order to continue the optimisation process. Cut out a piece of copper foil, ca. 2.5 x 3.5, holding it by means of a cleft match stick, probe the gate track between T1 and T2 and also between T2 and T3. Spots will be found where the power gain slightly increases. Remove the supply and then solder the copper foil to this point. These points will vary from PCB to PCB according to the normal range of manufacturing tolerances and that is why no exact place can be given before-hand. If it could have been, the foil's function would, of course, be carried out by an etching on the board! A fully optimised module will exhibit a noise figure of under 3 dB and a gain of some 20 dB. With careful construction and alignment, there should be no tendency to parasitic oscillation or any de-tuning effects upon placing or removing the covers.

11.

By means of a supplementary soldered-on foil to T1's input transformer, a noise-figure of 2.5 dB can be attained.

Finally, it may be added, the more trouble that is taken in the construction of this module the easier will be the alignment and a successful operation of this high-performance 10 GHz converter is assured.

3.5. Module XRM-1 Technical Data

Input frequency	10.368 - 10.370 GHz
IF	144 - 146 MHz
Noise-figure F (typ.)	2.5 dB
Overall gain (typ.)	20 dB
Required LO input pwr. at 2556 MHz	5 mW (min)
10.224 GHz LO output power	5 mW (min)
RF connectors:	
10 GHz input	SMA
LO output	SMA
IF output	BNC



Supply voltage (internally stabilised)	10 - 15 V
Supply current (typ.)	80 mA
Dimensions (w/o connectors)	74 x 111 x 30 (mm)
Weight	175 g

4. TRANSMIT MIXER XTM-1

This part of the description concerns itself with the 10 GHz transmit mixer XTM-1 which is built in accordance with the same principles as the local oscillator and the receive mixer. Actually, the transmit mixer can only be regarded in the same light as the receive mixer XRM-1, as the local-oscillator frequency for both modules is generated in the latter module. The two units, XRM-1 and XTM-1, therefore compliment one-another.

Of course, it is possible to build the mixer part only of the XTM-1 if a suitable local-oscillator source is available having a stable output frequency of 10.244 GHz. If this were the case, certain points in part 1 of the description should nevertheless be carefully read through and the recommendations followed. This is because, in general, all constructional hints are not repeated in subsequent chapters.

The printed-circuit material and the dimensions of the pre-fabricated board are identical with those of the receive mixer.

4.1. Circuit Details

The XTM-1 (fig. 13) translates the 2-metre drive signal linearly into the 10 GHz amateur band. Suitable modes for translation are SSB, CW, FM, and FM-ATV. The mixing process takes place in a linear GaAs-FET mixer (T1) which can give a clean power output of up to 0.1 mW. The following 30 dB linear amplifier is cavity-resonator coupled and presents a stable, spurious-free, 100 mW signal to the output.

The final stage of the XTM-1 has a genuine GaAs-FET device (T4) which is worked, both thermally and electrically, in a very stable fashion.

The local-oscillator signal is supplied to the transmit-mixer at 10.244 GHz and at a power of 5 mW. Two-metre signals of between 20 mW and 3 W can also be employed. This allows the use of any proprietary 2-metre transceiver e.g. FT290R.

4.2. Installation of the PCB XTM-1 into the Housing and Component Placement

1...14.

Read through the instructions given for component placement and general construction of the module XRM-1 and follow them step by step in the completion of this module. The XTM-1 shown in figures 14 and 15 show 3 resonator filters instead of the 2 for the receive module. Altogether, 14 board through-connections must be carried out.

The stiffening wall is located 42 mm from the wall carrying the BNC-connector (see fig. 14). This wall, again, is not used for shielding but purely for mechanical stability.

15.

Load, and solder in the remaining components (voltage regulator with de-coupling capacitors, potentiometer 51 Ω) in accordance with fig. 14 taking care to observe the component polarities.

This completes the work on the ground-plane side of the board.

16...22.

Please follow the instructions given for the receive module XRM-1. Altogether, 4 GaAs-FETs, one of which is a power device, must be soldered in (fig. 15).

23.

Carefully inspect, with a magnifying glass, all the soldered joints of the SMD components and the GaAs-FETs.

4.3. XTM-1 Components

- 1 x PCB XTM-1 (ready drilled and silvered)
- 1 x Proprietary tin-plate box (74 x 111 x 30) mm
- 1 x Tin-plate sheet 14 x 71 x 0.5 (mm)
- 4 x Tin-plate sheet 6 x 13 x 0.5 (mm)
- 1 x Carbon foam-plastic mat 72 x 108 x 6 (mm)
- 3 x Resonator cavity, silvered, M4 screw-thread in top. Ext. dia. 18 mm, int. dia. 16 mm, height ext. 11.5 mm, int. 9.5 mm

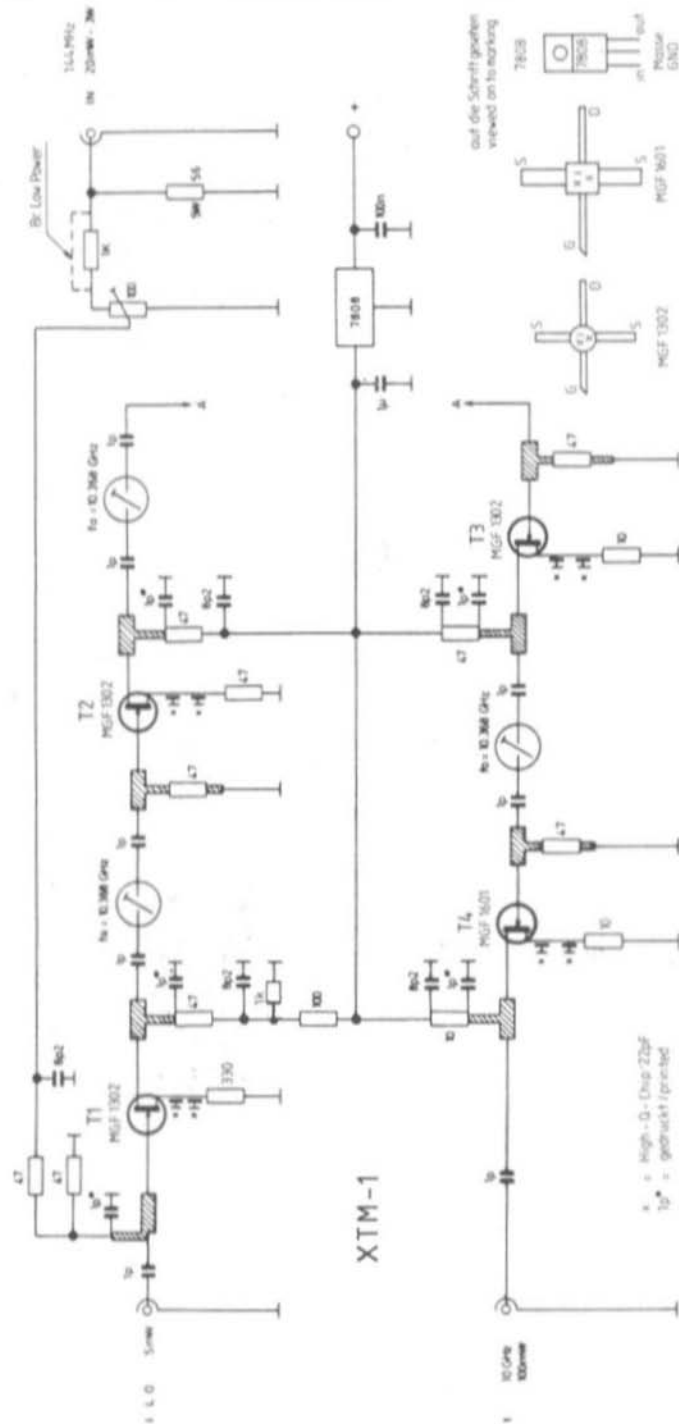

Fig. 13: The transmit module XTM-1 contains the transmit mixer (T1) and 3 power amplifiers as well as 3 filter circuits

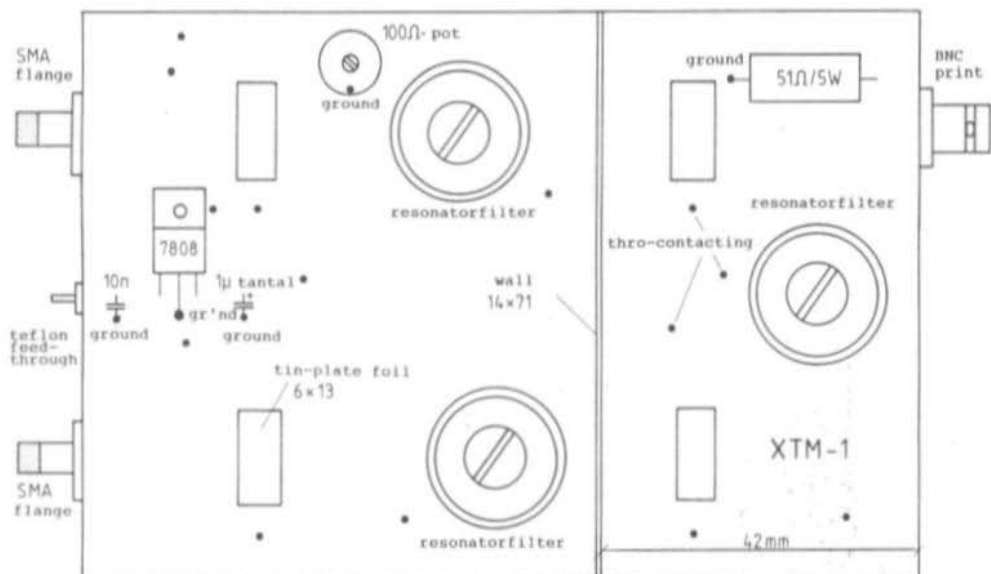

Fig. 14: XTM-1 ground-plane side showing filters, foils and through-contacting

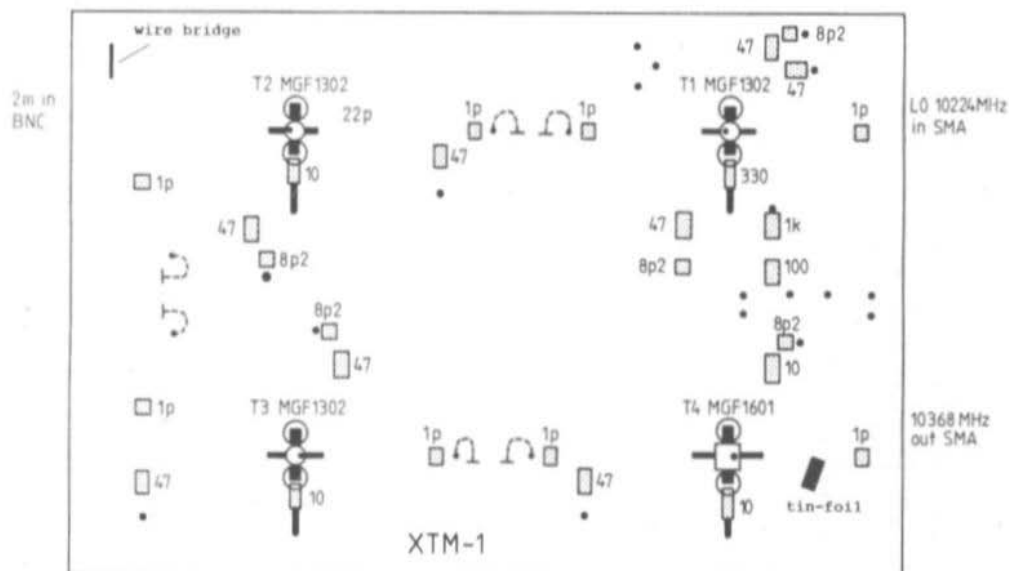

Fig. 15: XTM-1 microstrip-line side



- 3 x M4 brass grub-screws, overall length 8 mm
- 3 x Flat, brass hexagon M4 nuts, 2 mm thick
- 1 x Length of 0.5 mm dia. silvered wire:
10 cm long
- 1 x Resistor 51 Ω , 5 W
- 1 x Special potentiometer, upright mounting,
100 Ω
- 1 x Teflon through-connector
- 1 x BNC printed circuit connector
- 2 x SMA flange sockets
- 1 x Voltage regulator, 7808
- 3 x MGF 1302
- 1 x MGF 1601
- 1 x Tantalum cap. 1 μ F/35 V
- 1 x Capacitor 100 nF
- 1 x Copper sheet 10 x 20 x 0.05 (mm)
- 8 x High Q plate-capacitors 22 pF, 3.2 mm dia.,
0.25 mm thick

13 chip capacitors:

- 8 x 1 pF
- 5 x 8.2 pF

15 SMD resistors:

- 4 x 10 Ω
- 8 x 47 Ω
- 1 x 100 Ω
- 1 x 330 Ω
- 1 x 1 k Ω

4.4. Transmit-Mixer Alignment

If no spectrum analyser is available – and this will be the case for most constructors – a filter with coaxial in- and output-connectors together with a milli-wattmeter (100 - 300 μ W, e.g. thermal power meter) will be necessary.

Without these two items, the alignment is not possible!

The harmonic-free output signal is achieved by means of three resonator-filter circuits in tandem. The necessity of having test equipment will cause no great argument among SHF amateurs as many have discovered, that the lack of it has caused the abandonment of many a promising project.

The following alignment has been carried out several times and has been found to be the simplest method: –

1.

A tunable filter, 8 - 26 GHz with SMA connectors (8)(9), is connected to the input of a 10 GHz

receive converter (e.g. XRM-1). This is tuned until the test signal (from a transponder or signal generator (7)) is again detectable in the 2-metre transceiver.

The filter has now been tuned to exactly 10.368 GHz. The Q of such a filter (9) is so high that both the mirror image and injection frequency are sufficiently suppressed. The filter's insertion loss amounts to some 2 dB.

2.

The filter is then removed from the receiver, without detuning, it is used in this condition for the rest of the alignment procedure.

3.

Screw the M4 grub screws so that the top of the screw lies just under the top edge of the M4 lock-nut.

4.

Adhere the carbon foam-plastic mat to the inside of the cover and put the cover to the ground-plane side of the frame. Apply the supply voltage via a multimeter – a current of ca. 200 mA will flow upon switch-on.

5.

Switch the milli-wattmeter to high-range (max. 300 μ W) and connect it to the transmit output socket.

6.

Feed in the LO signal (5 mW min. at 10.224 GHz) and turn the transit-mixer potentiometer fully up. Feed ca. 100 mW CW or FM from a 2 m transceiver into the IF input socket.

7.

Tune the M4 grub screw of the first filter (between mixer-transistor and first linear amp.) carefully into the resonator until a small indication on the milli-wattmeter is visible. Adjust the range of the wattmeter accordingly.

8.

Temporarily stop the 2-metre signal and check that the milli-wattmeter indication falls to zero. If this is not the case, the tuning screw had been initially screwed-in too deep.

9.

Screw-in the M4 tuning screw of the second filter (between first and second linear amps.) carefully until the milli-wattmeter starts rising. The wattmeter will still be in the lower ranges.

10.

Turn the third filter's (between second amp. and

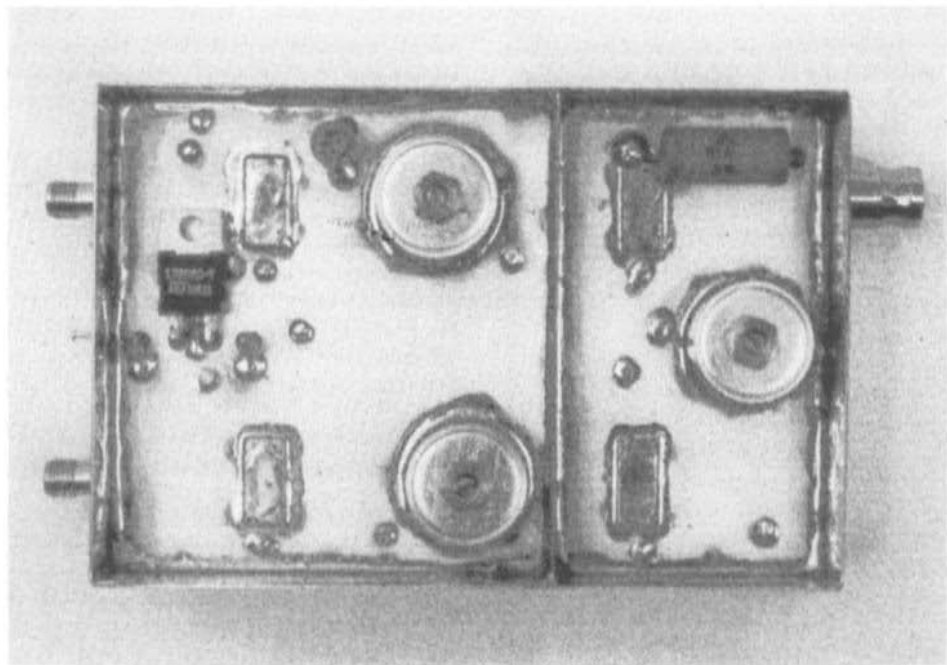

Fig. 16: The ground-plane side of the transmit mixer XTM-1 module

output stage) M4 tuning screw into the resonator until the milli-wattmeter shows a sudden rise in output power. Change the range accordingly – it should be in the 30 mW region. Temporarily switch-off the 2 m signal and check as in step 8. 11.

Change the milli-wattmeter range to 100 mW and carefully re-tune all filters for a maximum indication. As in the XRM-1 filters, the tuning screws will protrude some 4.5 mm into the body of the resonator. The top of the grub screw lies 0.5 mm under the top lip of the lock-nut.

Turn the drive down slowly with the mixer potentiometer until the saturation effects (just disappear. After removing the test filter, the output power must indicate ca. 100 mW. The current consumption on "send" alters only very slightly (a few mA) in the course of operation, as the amplifier is working in full class A. 12.

Turn the module around and take off the cover.

Move a small copper foil (2 x 3.5 mm) in contact along the PA drain lead towards the output transformer, holding it with a cleft matchstick, until the power output shows a clear increase. Remove the supply voltage and solder-on the copper foil to the spot which has been found.

The module XTM-1 is now ready for operation with an output power of 100 mW. However, with a few more adjustment procedures and depending upon the production tolerance spread of the semi-conductors, up to 3 dB more power output can be obtained.

Further matching measures can be undertaken in the driver stages which will vary from module to module. The procedure in step 12 should be undertaken very carefully and thoroughly. Output powers of at least 100 mW can always be obtained if careful construction and alignment procedures have been carried out.

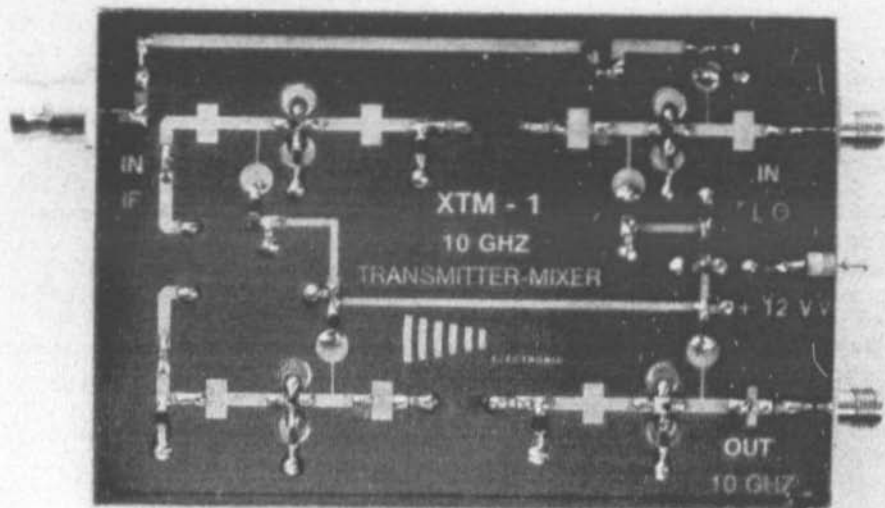

Fig. 17: The microstrip-line side of the XTM-1

A transmit-mixer module, aligned without a spectrum analyzer, has an LO suppression of at least 30 dB. Careful alignment, using the spectrum analyzer, will yield a suppression of over 40 dB.

If all the measures described have been properly and carefully carried out, a small, but stable, 10 GHz transmitter with a respectable output power is ready for operation. The output power can be increased by a further 6 - 10 dB by the employment of still more expensive power GaAs-FETs, such as e.g. MGF 2124 (1 W). Such a MGF 2124 power amplifier, placed in a sample XTM-1 module by the author, yielded an output power of 700 mW.

A further tip for the experienced constructor is that the employment of an HEMT in the input of the receiver mixer XRM-1 instead of the MGF 1303, improves the input noise figure to under 1.5 dB. The author is still conducting experiments in this area.

The author hopes, that with this detailed constructional article, all those SHF amateurs that have not, as yet, risked working with GaAs-FETs with their attendant specialised SHF PCB techniques, have been motivated to construct this 10 GHz Transverter. The conditions are very suitable for such a start in SHF construction with the very detailed instructions and sure-fire well-tried modules.

The author would now like to thank the following amateurs who helped to enable an alignment procedure to be evolved which did **not** include the use of a noise generator or a spectrum analyzer. Carsten Vieland, DJ 4 GC, Horst Fenger, DK 1 VC, and Bert Bruntink, DJ Ø PQ, have all described and built suitable test equipment. They have also engendered the employment of cavity resonators for this frequency band. The greatest gratitude is extended to the firm SSB-Electronic who, by their fruitful co-operation and component support, have helped to create a mature concept which will set the



standard in 10 GHz amateur radio technology for some time to come.

4.5. XTM-1 Module Technical Data

Input frequency:	144 - 146 MHz
Input RF power: (internally controlled)	20 mW - 3 W
Output frequency:	10.368 - 10.370 GHz
Output power (linear):	> 100 mW
10.224 GHz injection power (min):	5 mW
Harmonic suppression (typ.):	40 dB
3 dB Power-bandwidth (typ.):	25 MHz
RF Connectors:	
LO	
Output:	SMA
2-Metre input:	BNC
Supply Voltage: (int, stabilised):	10 - 15 VDC
Supply current (typ.):	180 mA
Dimensions (w/o connectors):	74 x 111 x 30 (mm)
Weight:	180 g

5. SOURCES OF LITERATURE USED IN THE ALIGNMENT OF MODULES XLO-1, XRM-1 AND XTM-1

- (1) Dahms, J., DC Ø DA: An Absorption Wavemeter for 70 MHz to 1350 MHz VHF COMMUNICATIONS Vol. 9, Ed. 2/1977, P. 90 - 97
- (2) SSB-Electronic: AFM 1500 b - Breitband-Frequenzmesser und Pegelanzeiger, 70 bis 1500 MHz, Katalog 88, VHF-UHF-SHF-Komponenten und Systeme
- (3) Vieland, C., DJ 4 GC: Präzisionsleistungsmesser von Gleichstrom bis in den Mikrowellenbereich. cq-DL 3/1986, S. 144
- (4) SSB-Electronic: Thermischer Leistungsmesser TPM 4, DC bis 11 GHz, Katalog 88, VHF-UHF-SHF-Komponenten und Systeme
- (5) SSB-Electronic: PM 1300 A-Präzisions-Wattmeter für den Bereich 10 MHz - 1500 MHz, Katalog 88, VHF-UHF-SHF-Komponenten und Systeme
- (6) Weiner, K., DJ 9 HO: UHF Absorptions Frequency Meter up to 2.5 GHz; The UHF-COMPENDIUM, Part 1 and 2: UHF-BASICS, Page 98
- (7) Fenger, H., DK 1 VC: Empfängerabgleichhilfe für 9 cm, 6 cm und 3 cm, cq-DL 8/1987, S. 492
- (8) Vieland, C., DJ 4 GC: Meß- und Hilfsmittel für das 10-GHz-Amateurfunkband, cq-DL 4/1987, S. 227
- (9) Vieland, C., DJ 4 GC: Tunable VHF to SHF Bandpass Filter VHF COMMUNICATIONS Vol. 18, Ed. 3/1986, P. 177 - 185

BRIEFLY SPEAKING...

Salient characteristic	BF966S	BF988	CF 139 X-plastic	
	BF996S	BF998	SOT-143	
Transconductance	18	24	30	mS
Gate source cap. C_{giss}	2.3	2.1	1	pF
Figure of merit g_{fs}/C_{giss}	7.8	11.4	30	mS/pF
Noise figure (800 MHz)	1.8	1	0.8	dB
Amplification	18	20	22	dB
Noise figure (1750 MHz)		3.3	1.8	dB
Amplification (1750 MHz)		12	17	dB
Working point (typ.):				
U_{DS}	15	8	5	V
U_{G2S}	4	4	2	V
Gate length	2	1	1.5	μm
Gate width	1250	1100	640	μm
The current $I_d = 10$ mA is set with U_{G1S} according to I_{dss} requires a U_{G1S} of	about 0	about 0	about -1	V

Table 1: The characteristic of the silicon (BF 966 S, BF 996 S, BF 988 S, BF 998 S) and gallium arsenid (CF 139, CF 739) tetrodes compared.

New tetrode-FETs in Si and GaAs

The new Si-MOS tetrodes, **BF 988** and **BF 998** have already been extensively described in VHF COMMUNICATIONS 3/88. The latter device has a gate 1 length of only $1 \mu\text{m}$ and an 800 MHz NF of 1 dB.

Now, again from Siemens, comes another GaAs-MES-FET tetrode which could become the workhorse for the 23/24 cm amateur band and for weather-satellite reception. It is the **CF 139** (X-plastic), **CF 739** (SOT-143). The salient data is shown in **table 1** in comparison with the aforementioned Si-tetrode and a older still device with a $2 \mu\text{m}$

gate 1 length. It is clear that the new GaAs-MESFET is intended for use in satellite-TV applications.

It is usual to find GaAs-FETs having only one gate to have particularly low noise-figures but they are not required in every application. The advantage of the MESFET is really apparent with its reluctance to self-oscillation and its ability for the gain to be controlled by the gate potential on gate 2. By way of comparison, look at the circuits of the old GaAs-MES-FETs (**S 3030** by TI and the **CF 300** by Telefunken).

DL 3 WR

From Siemens Components 26 (1988), ed. 6



Companion IC for battery operation opens new applications

Philips/Signetics have extended their family of companion ICs (NE 570, NE 571, NE 572) with a new type, **NE 575**. This has a supply voltage capability of 3 to 7 volts and therefore is eminently suitable for use in battery powered equipment (cordless telephones, band R/T, BBT sets and portable 10/24 GHz transceivers).

Companions compress the audio dynamic range on the transmit side and expand it on the receive side to restore it to the original dynamic range. This technique improves the signal-to-noise ratio of the softer audio passages and limits the louder peaks.

The NE 575 contains two identical, but separate from each other, circuits which are able, using a minimum of external components, (de-) coupling and time-constant etc, to be used in either a compressor or a compander circuit (**fig. 1**). In transceivers, half of the device compresses the microphone signal and the other half is used for expanding the received AF signal.

Another, albeit related, application is a circuit for automatic level control (ALC). The circuit shown in **fig. 2** holds the output level constant to within ± 0.5 dB whilst the input signal is varying with a dynamic range of 60 dB. This must be a good thing for the PA driver.

DL 3 WR from Valvo sources

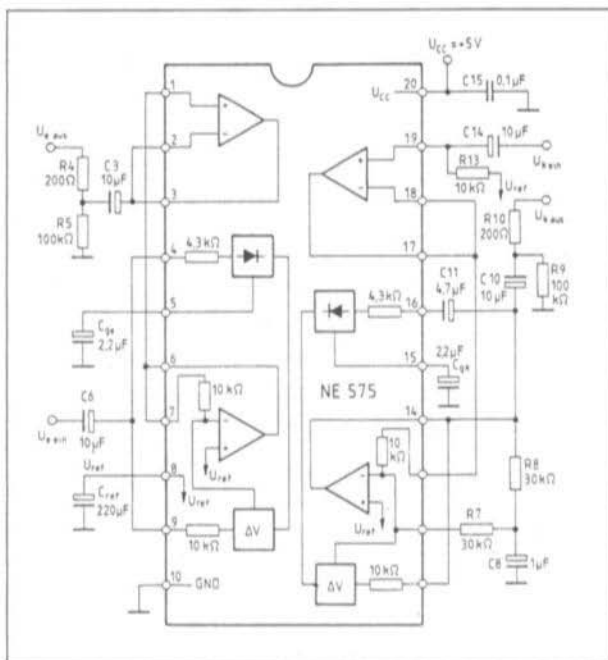

Fig. 1: Compressor/expander circuits using the NE 575

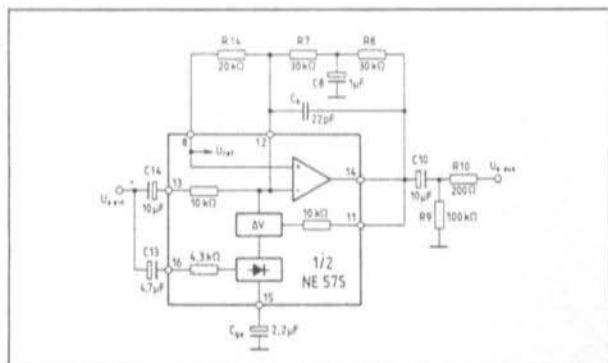

Fig. 2:
ALC circuit using the NE 575

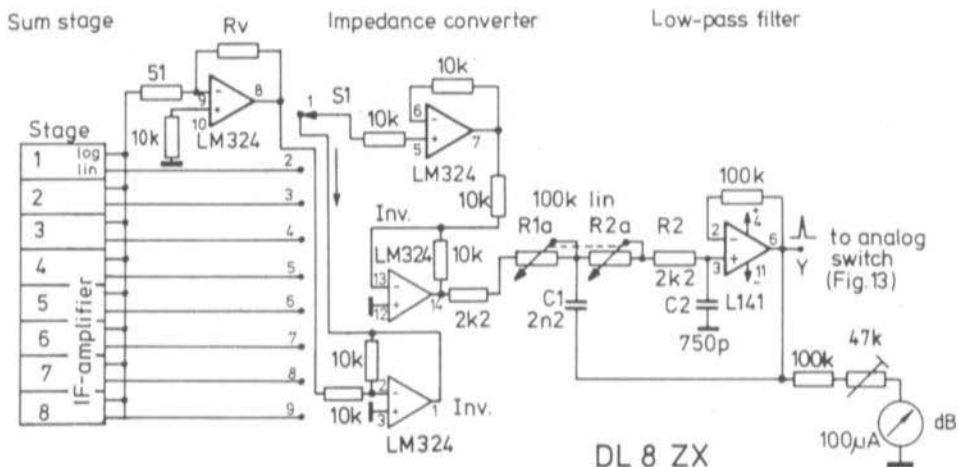

Fig. 11: Generation of the Y-signal and indicator circuit (this is the modified circuit)

Spectrum Analyzer (E. Berberich, DL 8 ZX)

In VHF COMMUNICATIONS 4/1980 a universal HF unit for a spectrum analyzer was described by DL 8 ZX. Although this project is more than a few

years old now, queries are still rolling in as it seems to evoke continuing interest. The author would therefore like to present an improvement now.

When switching between log. and lin. displays, the polarity

is reversed so that all signals point downwards.

The modification which corrects this is shown below in **fig. 11**. This makes use of the two free Op-Amps in the LM 324.



We accept **VISA Credit Card, Eurocard** (Access/Master Card) and only require the order against your signature, card number and its expiry date.

VHF COMMUNICATIONS / UKW-BERICHTE



UKWberichte T. Bittan OHG · Jahnstr. 14 · P.O.Box 80 · D-8523 Baiersdorf
Tel. West Germany 9133 47-0. For Representatives see cover page 2

MATERIAL PRICE LIST OF EQUIPMENT

described in edition 3/1989 of VHF COMMUNICATIONS

YT3MV	DSP Computer for Radio Amateur Applications	Art.No.	ed.2/88, 1 + 2/89
Set of PCBs, progr. EPROM, operating system V.7.2.	Contains: PCBs YT3MV 003 (bus), , 004, 005, 006 (4 x), 007, 008 and 009; a programmed EPROM, a set of copies of all diagrams and component lay-out plans (in A4), the operating-system manual.	6004	DM 1050.00
YT3MV 010	Interface for KR-5600 Rotators		ed. 1 + 2/89
	PCB, programmed EPROM, together with A4 copies of circuit schematics and component location plans	6003	DM 100.00
User software			upon request
DB1NV	Spectrum Analyser 0 - 500/1500 - 1000 MHz		ed. 2 + 3/89
Component kit (4 modules)	kit contains the 4 PCBs DB1NV 006, 007, 008, 009 together with the 4 drilled tin-plate housings with feed-throughs (caps + PTFE) and SMC sockets	6005	DM 1725.00
Completed modules (4)	aligned and tested	3302	DM 2698.00
DCØDA	10 GHz Transverter System "microline 3"		ed. 2 + 3/89
XLO-1	Oscillator		ed. 2/89
Kit	Contains all original components in chapter 2.3.	6601	DM 178.00
XRM-1	Receive mixer		ed. 3/89
Kit	Contains all original components in chapter 3.3.	6603	DM 345.00
XTM-1	Transmit mixer		ed. 3/89
Kit	Contains all original components in chapter 4.3.	6605	DM 355.00
Original Johansson trimming tool for μ W trimmer		6607	DM 18.50

Banker's order

Owing to an enlargement to our data processing organization we are able to offer an additional service to our subscribers with a **German** bank account. From January 1990 you will be able to pay the magazine subscription and other orders by banker's order. Ask for the necessary pro-forma.



UKWberichte T. Bittan OHG · Jahnstr. 14 · P.O.Box 80 · D-8523 Baiersdorf

Tel. West Germany 9133 47-0. For Representatives see cover page 2



A very detailed and comprehensive

AMATEUR RADIO PROGRAM

for the **ATARI ST**

de DK4BV ©

- Terminal program for packet radio and AMTOR
- RTTY program
- Amateur logbook
- Contest operation
- Antenna headings and distance calculations
- Determines moon and satellite positions
- CW trainer and much more!

Description in VHF Communication 3/89.



Program diskette in English
(version 10.5x)

Art.No.: 3403/9.x **DM 190.00**

Please give callsign and QTH
location code when ordering!



Telecommunications, VHF-Communications - UKW-Technik Terry D. Bittan
Jahnstraße 14, D-8523 Baierdorf, Telefon (091 33) 470, Telex 629 887



MICRO-AMP with VOX/PTT

Low-noise GaAs-FET pre-amplifiers with outstanding features and favourable prices

2-m model MC-2 **DM 249.50**
70-cm model MC-70 **DM 259.00**

These are two of the low-noise mast-mounted pre-amplifiers of the

SSB-Electronic series

Ask for the Shortform Catalogue in English (free of charge)

Obtainable for original prices from:



Telecommunications, VHF-Communications - UKW-Technik Terry D. Bittan
Jahnstraße 14, D-8523 Baierdorf, Telefon (091 33) 470, Telex 629 887



PC/SAT Weather Satellite Reception on a PC/AT

For the First Time!

Reception and processing of weather satellite pictures on any standard PC/AT or a compatible.

HARDWARE

- Antenna for 1.7 GHz (Yagi antenna with dipole or 90 cm offset parabolic antenna).
- Low-noise 1.7 GHz preamplifier (special preamplifier with only a 1.2 dB noise figure and a gain of 38 dB).
- Down-converter/receiver for RF translation and demodulation of the satellite's signal.
- PC/SAT interface - slots easily into a free AT/XT expansion-slot.
- PC/AT or compatible with the following basic equipment:
 - 286-processor
 - 640 kbyte and 1 Mbyte (min.) extended memory
 - Hard disk drive with at least 6.5 Mbyte free
 - EGA card or higher
 - EGA monitor



User-friendly SOFTWARE

written in C and Assembler 286

- Automatic reception
- Reception schedule:
The reception menu contains all METEOSAT transmissions listed with both time and format. Automatic reception by simply "clicking it up".
- Picture format
All pictures are stored on the hard disk in full format. There are three picture presentation formats:
 - 800 x 800 full resolution
 - 640 x 350 reduced resolution
 - 640 x 350 geographically corrected
- Zoom/histogram
The pictures may be enlarged up to a factor of x10. A histogram is computed for the selected sector.
- Colour
A colour table comprising 50 selectable colours is available for various picture spectral ranges.
- Time lapse/movie of up to 16 pictures;
can be moved forwards and backwards.

Ask for a Demo-program with satellite pictures (DM 20.-) together with further information - cash or check with order.



UKWtechnik

UKW-Technik
T. Bittan GmbH
P. O. Box 80, Jahnstraße 14
D-8523 Baiersdorf
Fed. Rep. of Germany

Tel. (49) 9133-4715
Tlx. (49) 9133-4718
Tx. 629887 ukwdo d



Plastic Binders for VHF COMMUNICATIONS

- Attractive plastic covered in VHF blue
- Accepts up to 12 editions (three volumes)
- Allows any required copy to be found easily
- Keeps the XYL happy and contented
- Will be sent anywhere in the world for DM 10.00 including surface mail

Order your binder via the national representative or directly from the publishers of VHF COMMUNICATIONS (see below)

Prices for VHF COMMUNICATIONS

Subscription	Volume	Individual copy
VHF COMMUNICATIONS 1988 to 1989	DM 25.00	each DM 7.50
VHF COMMUNICATIONS 1987	DM 24.00	each DM 7.00
VHF COMMUNICATIONS 1986	DM 24.00	each DM 7.00
VHF COMMUNICATIONS 1985	DM 20.00	each DM 6.00
VHF COMMUNICATIONS 1980 to 1984	DM 16.00	each DM 4.50
VHF COMMUNICATIONS 1975	DM 12.00	each DM 3.50
VHF COMMUNICATIONS 1976 to 1979 (incomplete, only 3 editions)	DM 9.00	each DM 3.50

Individual copies out of order, incomplete volumes, as long as stock lasts:

1/1970, 2/1971, 1/1972, 2/1972, 4/1972,
2/1973, 4/1973, 1/1974, 3/1974

each DM 2.00
each DM 2.00

Plastic binder for 3 volumes

DM 10.00

We shall not be able to reprint editions which are older than 6 years.

All prices including surface mail

When ordering 3 complete volumes, a free binder is included!



UKWberichte Terry D. Bittan · Jahnstr. 14 · Postfach 80 · D-8523 Baiersdorf

Tel. West Germany 9133 47-0. For Representatives see cover page 2

